

REVISIONS			
ISS	ZONE	DESCRIPTION	APPROVED\DATE
B	A-1	DRAWING NO. WERE CHANGED ON NO.3, NO.5, NO.6,	
	B-1	NO.7 AND NO.9\TONY. T\09-23-96'	
C	A-1	NO.2 AND NO.4 WERE CHANGED\TONY. T\12-10-96'	

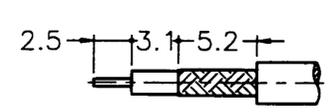

RECOMMENDED CABLE STRIPPING DIM'S

業務部

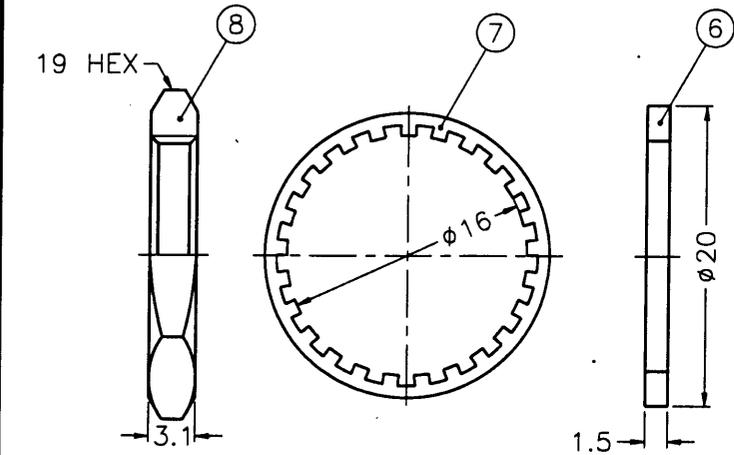
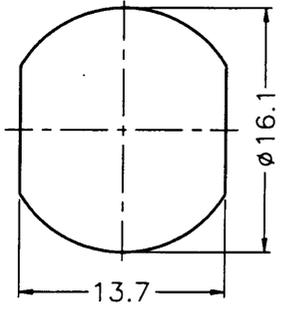

RECOMMENDED MOUNTING HOLE

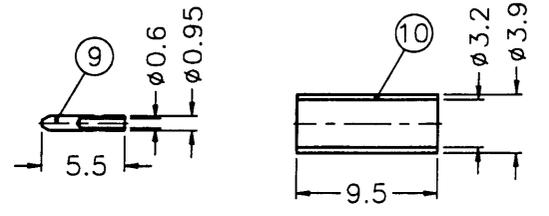
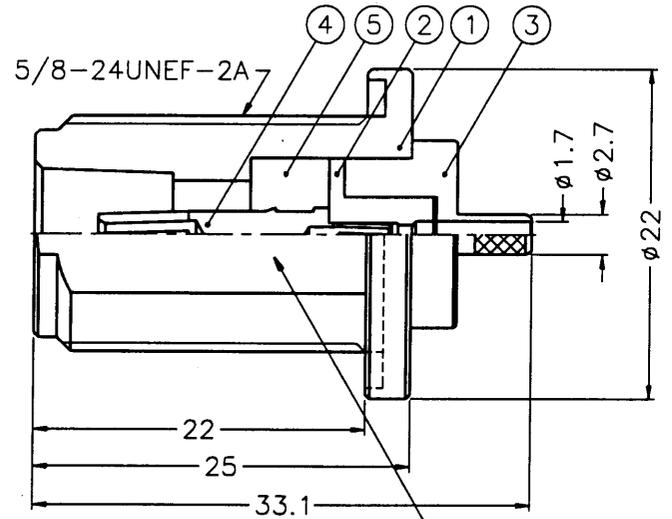

- NOTES: FINISH (PLATING THICKNESS IN MICRO-INCHES)
- BRASS PER QQ-B-626, ALLOY 360, 1/2 H
 - BRASS PER QQ-B-613, COMP 260, HARD TEMP
 - NICKEL PL. 100 MIN. OVER COPPER PL. 50 MIN. SILVER PL. 80 MIN. OVER COPPER PL. 50 MIN.
 - PHOSPHOR BRONZE PER QQ-B-750, COMP A, 1/2 H
 - GOLD PL. MIN. OVER NICKEL PL. 50 MIN. OVER COPPER PL. 50 MIN. SILVER PL. 100 MIN. OVER NICKEL PL. 50 MIN. OVER COPPER PL. 50 MIN.
 - TEFLON MIL-P-19468

出圖
85.12.11
R&D

NO.	DESCRIPTION	MATERIAL	FINISH	Q'TY	DRAWING NO.
10	FERRULE			1	FR-39/32X95
9	CONTACT PIN			1	B50003-9-0.6
8	HEX NUT			1	HN19-5/8-24X31
7	LOCK WASHER			1	LW-19/16X06
6	GASKET	SILICONE	RED	1	GS-20/16X15
5	INSULATOR		NATURAL	1	N6421G1-5T-50
4	CONTACT PIN			1	N6421G1-4-1.05 -B
3	BARREL			1	N6421G1-3-27/ 17
2	INSULATOR		NATURAL	1	N6421G1-2T-50 -B
1	BODY			1	N7400-1

DIMENSIONS ARE IN MILLIMETERS				PART NO.	
UNLESS OTHERWISE SPECIFIED TOLERANCES				APPROVED <i>Tony E</i> DATE 12-10-96'	
0.5-6	= ±0.2			CHECKED <i>Golden W</i> DATE 12-10-96'	
6-30	= ±0.4			DRAWN <i>Golden W</i> DATE 12-10-96'	
30-120	= ±0.6				
120-315	= ±1				
315-1000	= ±1.6				
1000-2000	= ±2.4				

<p>KAI JACK INDUSTRIAL CO., LTD. TAINAN TAIWAN R.O.C.</p>	
TITLE N BULKHEAD CRIMP JACK (FOR RG-174/U,188A/U,316/U)	
DRAWING NO. KJ-N6421G1-316U-50	
FILE NO. F:\DWG\N\6421G1\316U-50	

F
E
D
C
B
A

F
E
D
C
B
A