

| ISS | ZONE | DESCRIPTION \ PER REQUEST \ DATE            |
|-----|------|---|
| B   | A-1  | NO.4 WAS CHANGED \ RD-DM890518011\05-18-00' |
| C   | A-1  | NO.5 WAS CHANGED \ RD-DM89061701C\06-17-00' |

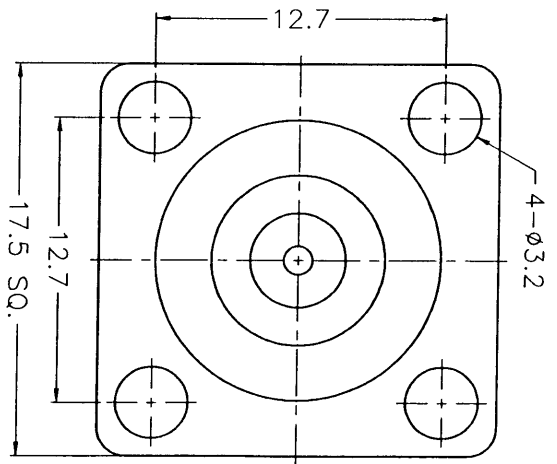
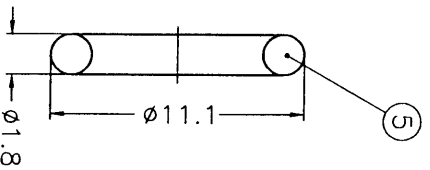
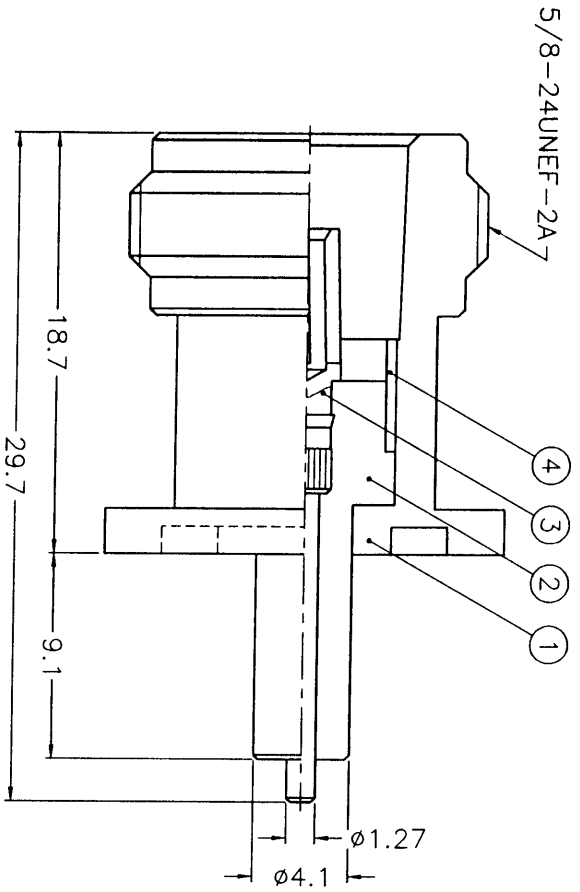

- NOTES: FINISH (PLATING THICKNESS IN MICRO-INCHES)
1. BRASS PER QQ-B-626
  2. NICKEL PL. 100 MIN. THICK OVER COPPER STRIKE
  3. PHOSPHOR BRONZE PER QQ-B-750
  4. GOLD PL. 3 MIN. THICK OVER NICKEL PL. 100 MIN. THICK OVER COPPER STRIKE
  5. TEFLON MIL-P-19468
  6. SILICONE, CLASS 20 GRADE 70 OF SPEC. ZZ-R-765E

| NO. | DESCRIPTION | MATERIAL | FINISH  | Q'TY | DRAWING NO.   |
|-----|-------------|----------|---------|------|---------------|
| 1   | BODY        | NOTE 1   | NOTE 2  | 1    | N7550-1       |
| 2   | INSULATOR   | NOTE 5   | NATURAL | 1    | N7550-2T-50   |
| 3   | CONTACT PIN | NOTE 3   | NOTE 4  | 1    | N7550-3       |
| 4   | RING        | NOTE 1   | NOTE 2  | 1    | N-JACK-LR1    |
| 5   | GASKET      | NOTE 6   | RED     | 1    | GS-111/75XD18 |

DIMENSIONS ARE IN MILLIMETERS  
UNLESS OTHERWISE SPECIFIED

| TOLERANCES       |
|------------------|
| 0.5-6 = ±0.2     |
| 6-30 = ±0.4      |
| 30-120 = ±0.6    |
| 120-315 = ±1     |
| 315-1000 = ±1.6  |
| 1000-2000 = ±2.4 |

| SCALE | 3/1 | ISSUE | C |
|-------|-----|-------|---|
|       |     |       |   |

PART NO.

APPROVED

CHECKED

DRAWN

DATE

DATE

DATE

# Amphenol - Kai Jack

TAINAN TAIWAN

N PANEL RECEPT. JACK

DRAWING NO. KJ-N6551E1-NT3G-50

FILE NO. F:\DWG\N\6551E1\50\NT3G

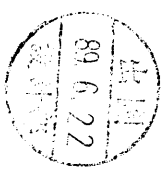

BRD-DR(901)