

1 2 3 4 5 6 7 8

REVISIONS		
ISS	ZONE	DESCRIPTION\PER REQUEST\DATE

業務部

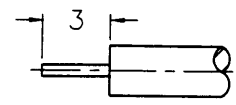

RECOMMENDED
CABLE STRIPPING DIM'S
(建議剝線尺寸)

F

E

D

C

B

A

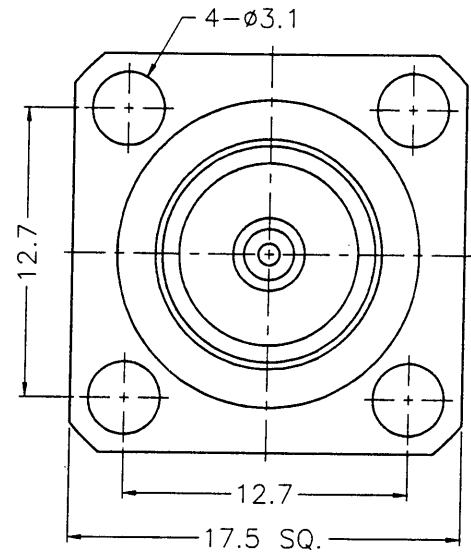
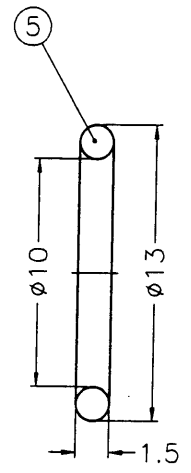
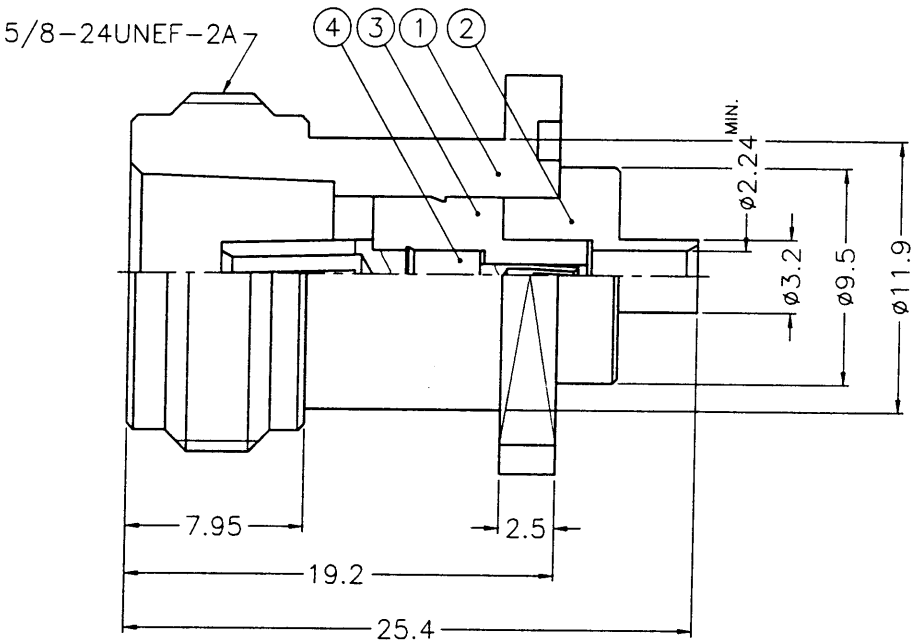

- NOTES: FINISH (PLATING THICKNESS IN MICRO-INCHES)
- BRASS PER QQ-B-626
 - PHOSPHOR BRONZE PER QQ-B-750
 - NICKEL PL. 100 MIN. THICK OVER COPPER STRIKE
 - GOLD PL. 3 MIN. THICK OVER NICKEL PL. 100 MIN. THICK OVER COPPER STRIKE
 - TEFLON MIL-P-19468

出圖
2008.8.28
設計部

DIMENSIONS ARE IN MILLIMETERS		PART NO.
UNLESS OTHERWISE SPECIFIED TOLERANCES		APPROVED <i>Mark</i> DATE 08-24-00'
0.5-6 = ±0.2		CHECKED <i>Jacky</i> DATE 08-24-00'
6-30 = ±0.4		DRAWN <i>Sola</i> DATE 08-24-00'
30-120 = ±0.6		
120-315 = ±1		
315-1000 = ±1.6		
1000-2000 = ±2.4		

Amphenol - Kai Jack	
TAINAN TAIWAN	
TITLE N PANEL DIRECT SOLDER JACK (FOR .085", .086" CABLE)	
DRAWING NO. KJ-N6581A5-N/3GT3G-.085-50	
FILE NO. F:\DWG\N\6581A5\085-50\N3GT3G	

NO.	DESCRIPTION	MATERIAL	FINISH	Q'TY	DRAWING NO.
5	GASKET	SILICONE	RED	1	GS-13/10XD15
4	CONTACT PIN	NOTE 2	NOTE 4	1	N6581A5-4
3	INSULATOR	NOTE 5	NATURAL	1	N6581A5-3T-50
2	SOLDER BODY	NOTE 1	NOTE 4	1	N6581A5-2-32/224
1	BODY	NOTE 1	NOTE 3	1	N6581A5-1

SCALE	3/1	ISSUE	A
-------	-----	-------	---

1 2 3 4 5 6 7 8