

1 2 3 4 5 6 7 8

REVISIONS		
ISS	ZONE	DESCRIPTION\PER REQUEST\DATE

SALVO

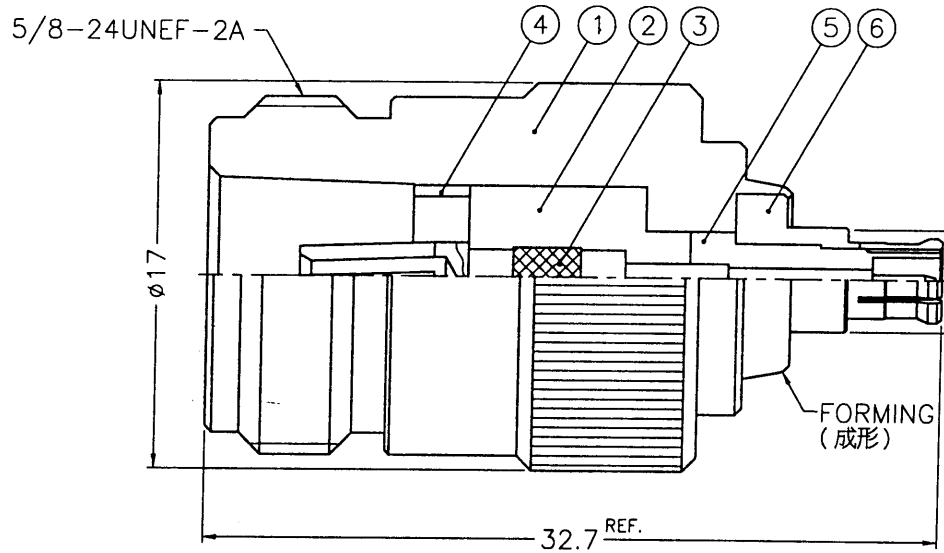

- NOTES: FINISH (PLATING THICKNESS IN MICRO-INCHES)
1. BRASS PER QQ-B-626
 2. NICKEL PL. 100 MIN. THICK OVER COPPER STRIKE
 3. PHOSPHOR BRONZE PER QQ-B-750
 4. GOLD PL. 3 MIN. THICK OVER NICKEL PL. 100 MIN. THICK OVER COPPER STRIKE
 5. TEFLON MIL-P-19468
 6. BERYLLIUM COPPER PER QQ-C-530

ISSUED
2003. 8. 15
R&D

NO.	DESCRIPTION	MATERIAL	FINISH	Q'TY	DRAWING NO.	SCALE	3/1	ISSUE	A1	FILE NO.	F:\DWG\NF\MCXM2\50\NT3G
6	BODY	NOTE 6	NOTE 2	1	SMAM-MCXM1-5-B	DIMENSIONS ARE IN MILLIMETERS					PART NO.
5	INSULATOR	NOTE 5	NATURAL	1	SMAF-MCXM1-2-B	UNLESS OTHERWISE SPECIFIED TOLERANCES					APPROVED
4	RING	NOTE 1	NOTE 2	1	N-JACK-LR2	0.5-6 = ±0.2					DATE
3	CONTACT PIN	NOTE 3	NOTE 4	1	CP00ACF01A	6-30 = ±0.4					CHECKED
2	INSULATOR	NOTE 5	NATURAL	1	NS00AGH01A	30-120 = ±0.6					DATE
1	BODY	NOTE 1	NOTE 2	1	BD00ABW01A	120-315 = ±1					DRAWN
						315-1000 = ±1.6					DATE
						1000-2000 = ±2.4					08-12-03'
<p style="text-align: center;">Amphenol Danbury,CT,USA-Tainan,Taiwan-Shenzhen,China</p> <p style="text-align: center;">TITLE N JACK TO MCX PLUG ADAPTOR</p> <p style="text-align: center;">DRAWING NO. NF-MCXM2-NT3G-50</p> <p style="text-align: center;">ITEM NO. 03F-08M2-NA-5-F</p>											

1 2 3 4 5 6 7RD-DR 19069 8