

1 2 3 4 5 6 7 8

業務部

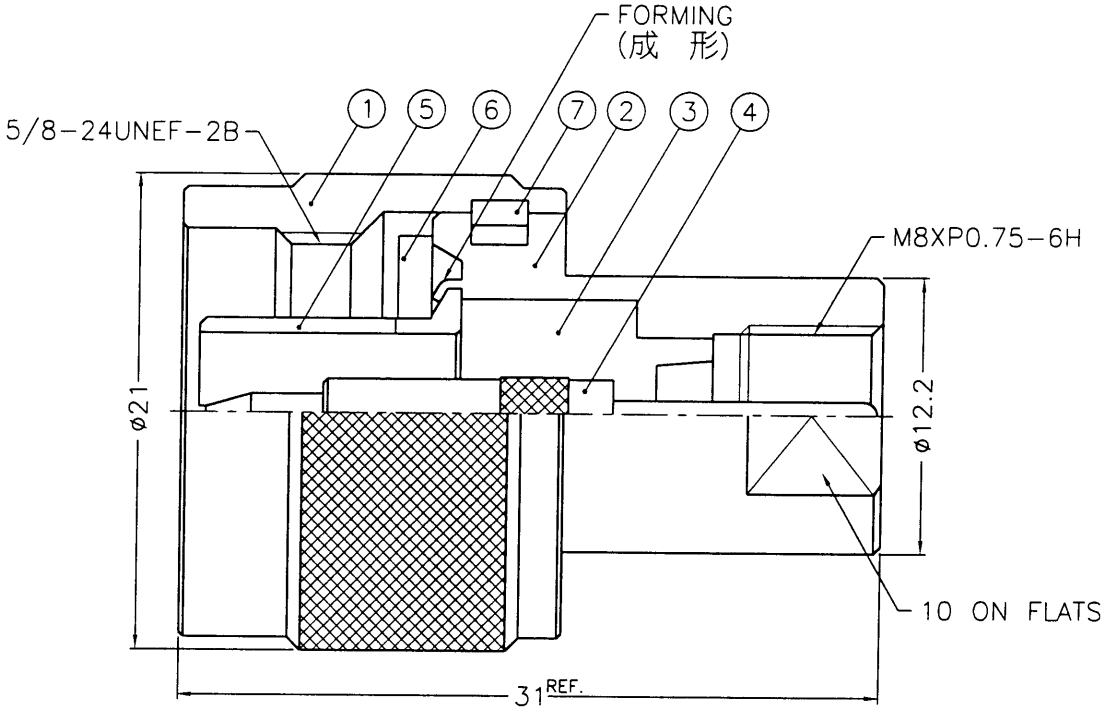

NOTES: FINISH (PLATING THICKNESS IN MICRO-INCHES)  
 1. BRASS PER QQ-B-626  
 2. NICKEL PL. 100 MIN. THICK OVER COPPER STRIKE  
 3. GOLD PL. 3 MIN. THICK OVER NICKEL PL. 100 MIN. THICK OVER COPPER STRIKE  
 4. TEFLON MIL-P-19468

88.5.07

7	RETAINER RING	SUS 304	NATURAL	1	N5000-7-C	DIMENSIONS ARE IN MILLIMETERS UNLESS OTHERWISE SPECIFIED TOLERANCES 0.5-6 = ±0.2 6-30 = ±0.4 30-120 = ±0.6 120-315 = ±1 315-1000 = ±1.6 1000-2000 = ±2.4	PART NO.			TITLE N MALE TO FME MALE ADAPTOR	
6	GASKET	SILICONE	RED	1	GS-156/8X15		APPROVED <i>Mark C</i> DATE 05-05-99'				DRAWING NO. NM-FMEM-NT3G-50
5	CONTACT BODY	NOTE 1	NOTE 2	1	N5000-5		CHECKED <i>Mark C</i> DATE 05-05-99'				
4	CONTACT PIN	NOTE 1	NOTE 3	1	FME2071N1-4		DRAWN <i>Solo</i> DATE 05-05-99'				FILE NO. F:\DWG\NM\FMEM\50\NT3G
3	INSULATOR	NOTE 4	NATURAL	1	FME2071N1-3T-50						
2	BODY	NOTE 1	NOTE 2	1	FME2071N1-2						
1	SHELL	NOTE 1	NOTE 2	1	N5000-1-B						
NO.	DESCRIPTION	MATERIAL	FINISH	Q'TY	DRAWING NO.	SCALE	3/1	ISSUE	A		

80072058

F  
E  
D  
C  
B  
A

F  
E  
D  
C  
B  
A

1 2 3 4 5 6 7 8