

1 2 3 4 5 6 7 8

REVISIONS		
ISS	ZONE	DESCRIPTION\PER REQUEST\DATE

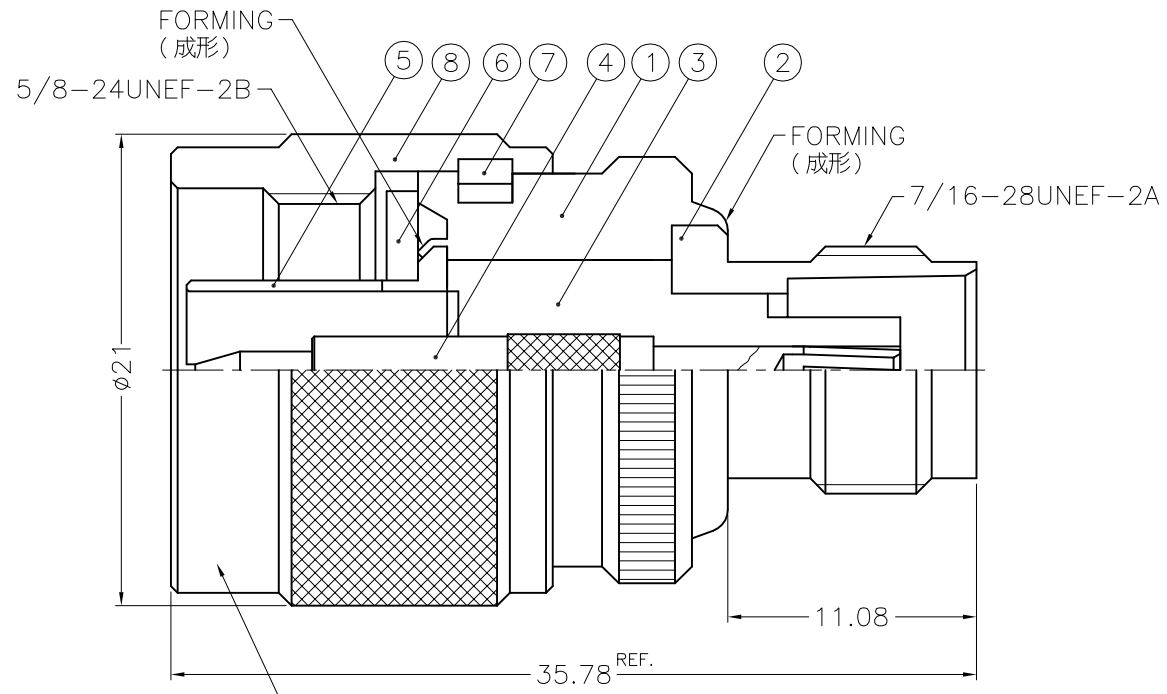

- NOTES: FINISH (PLATING THICKNESS IN MICRO-INCHES)
1. BRASS PER QQ-B-626
 2. PHOSPHOR BRONZE PER QQ-B-750
 3. NICKEL PL. 100 MIN. THICK OVER COPPER STRIKE
 4. GOLD PL. 3 MIN. THICK OVER NICKEL PL. 100 MIN. THICK OVER COPPER STRIKE
 5. TEFLON MIL-P-19468

NO.	DESCRIPTION	MATERIAL	FINISH	Q'TY	DRAWING NO.
8	SHELL	NOTE 1	NOTE 3	1	N5000-1-B
7	RETAINER RING	SUS 304	NATURAL	1	N5000-7-C
6	GASKET	SILICONE	RED	1	GS-156/8X15
5	CONTACT BODY	NOTE 1	NOTE 3	1	N5000-5
4	CONTACT PIN	NOTE 2	NOTE 4	1	NM-BF1-4
3	INSULATOR	NOTE 5	NATURAL	1	NM-BF1-3
2	BODY	NOTE 1	NOTE 3	1	BD02ACD01A
1	BODY	NOTE 1	NOTE 3	1	NM-SMAF1-2

DIMENSIONS ARE IN MILLIMETERS				PART NO.	
UNLESS OTHERWISE SPECIFIED TOLERANCES 0.5-6 = ±0.2 6-30 = ±0.4 30-120 = ±0.6 120-315 = ±1 315-1000 = ±1.6 1000-2000 = ±2.4				APPROVED	DATE
					07-23-02'
				CHECKED	DATE
					07-23-02'
				DRAWN	DATE
	07-23-02'				
SCALE	3/1	ISSUE	A	FILE NO.	F:\DWG\NM\TF1\50\NT3G

Amphenol - Kai Jack	
TAINAN TAIWAN	
TITLE N MALE TO TNC FEMALE ADAPTOR	
DRAWING NO. KJ-NM-TF1-NT3G-50	
ITEM NO. 03M-02F1-NA-5-F	

1 2 3 4 5 6 7 8