

1 2 3 4 5 6 7 8

REVISIONS		
ISS	ZONE	DESCRIPTION\PER REQUEST\DATE

業務部

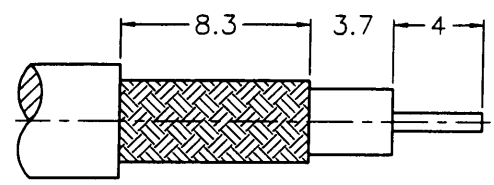

RECOMMENDED
CABLE STRIPPING DIM'S
(建議剝線尺寸)

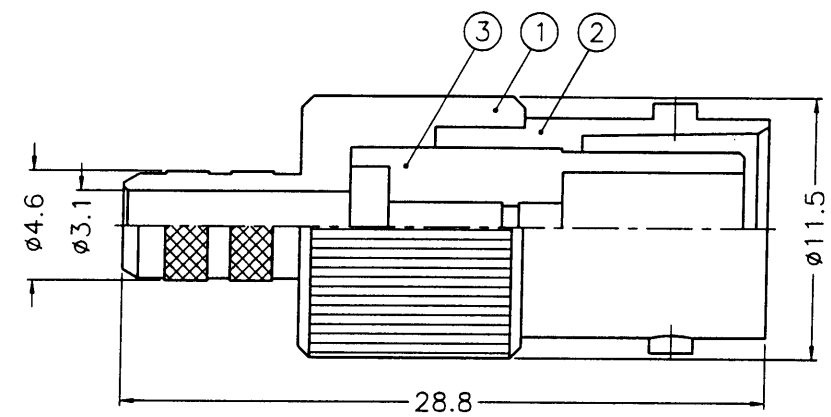
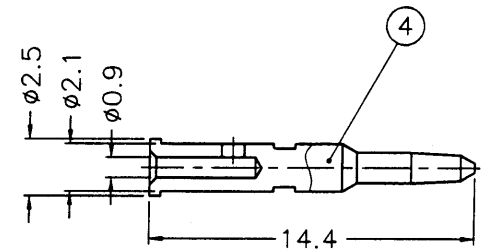
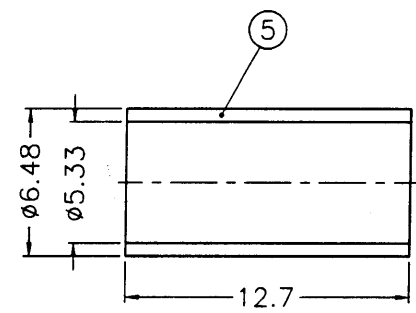

NOTES: FINISH (PLATING THICKNESS IN MICRO-INCHES)
 1. BRASS PER QQ-B-626
 2. NICKEL PL. 100 MIN. THICK OVER COPPER STRIKE
 3. GOLD PL. 3 MIN. THICK OVER NICKEL PL. 100 MIN. THICK OVER COPPER STRIKE
 4. TEFLON MIL-P-19468

出圖
2001. 3. 15
設計部

- 1. CRIMPED FERRULE
HEX CRIMP SIZE .213"
- 2. CRIMPED CONTACT PIN
HEX CRIMP SIZE .068"

DIMENSIONS ARE IN MILLIMETERS					PART NO.			Amphenol - Kai Jack	
UNLESS OTHERWISE SPECIFIED TOLERANCES					APPROVED			TAINAN TAIWAN	
5	FERRULE	COPPER	NOTE 2	1	FR-648/533X 127C	0.5-6 = ±0.2 6-30 = ±0.4 30-120 = ±0.6 120-315 = ±1 315-1000 = ±1.6 1000-2000 = ±2.4	DATE	TITLE	
4	CONTACT PIN	NOTE 1	NOTE 3	1	RT6121A1-4-25 /09-B		03-14-01'	BNC REVERSE POLARITY CRIMP JACK	
3	INSULATOR	NOTE 4	NATURAL	1	RT6121A1-3T-50		DATE	DRAWING NO.	
2	BODY	NOTE 1	NOTE 2	1	RB6421G1-2		03-14-01'	KJ-RB6121A1-NT3G-58U-50	
1	HOUSING	NOTE 1	NOTE 2	1	B70000-1-46/31		DATE	FILE NO. F:\DWG\RB\6121A1\58U-50\NT3G	
NO.	DESCRIPTION	MATERIAL	FINISH	Q'TY	DRAWING NO.	SCALE	3/1	ISSUE	A

R08DR11841

F
E
D
C
B
A

F
E
D
C
B
A

1 2 3 4 5 6 7 8