

1 2 3 4 5 6 7 8

REVISIONS			
ISS	ZONE	DESCRIPTION\PER REQUEST\DATE	

SALES

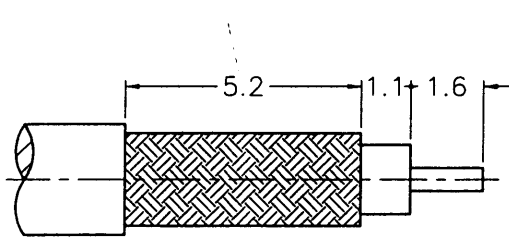

RECOMMENDED
CABLE STRIPPING DIM'S
(建議剝線尺寸)

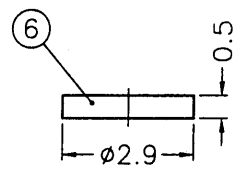
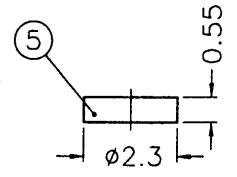
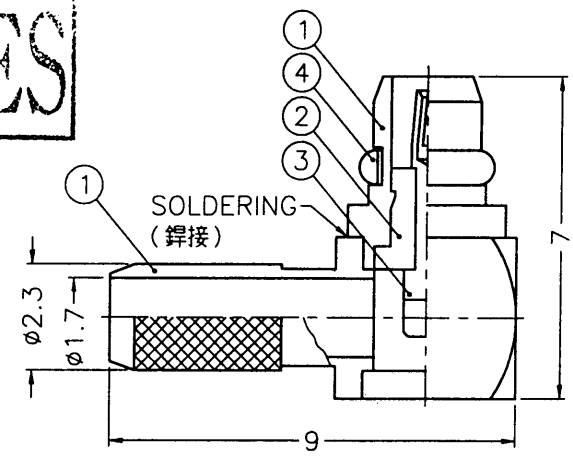
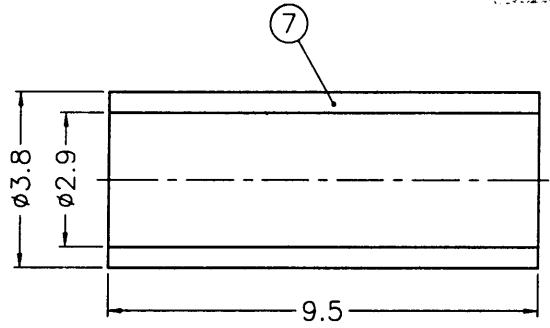

- 1. CRIMPED FERRULE, HEX. CRIMP SIZE #128"
- 2. CONTACT PIN TO SOLDER

18-SEP
2003. 2. 12
P.D.

NOTES: FINISH (PLATING THICKNESS IN MICRO-INCHES)
 1. BRASS PER QQ-B-626
 2. BRASS PER QQ-B-613
 3. GOLD PL. 3 MIN. THICK OVER NICKEL PL. 100 MIN. THICK OVER COPPER STRIKE
 4. BERYLLIUM COPPER PER QQ-C-530
 5. GOLD PL. 30 MIN. THICK OVER NICKEL PL. 100 MIN. THICK OVER COPPER STRIKE
 6. TEFLON MIL-P-19468

NO.	DESCRIPTION	MATERIAL	FINISH	Q'TY	DRAWING NO.
7	FERRULE	COPPER	NOTE 3	1	FRO0AAE37A
6	COVER	NOTE 2	NOTE 3	1	CV-29X05-T
5	INSULATOR	NOTE 6	NATURAL	1	MMCX1112A1-004-6T-B
4	RETAINER RING	NOTE 4	NOTE 3	1	MMCX1121A1-5-D
3	CONTACT PIN	NOTE 4	NOTE 5	1	CP09ABA01A
2	INSULATOR	NOTE 6	NATURAL	1	NS00ADD03A
1	HOUSING WITH BODY	NOTE 1	NOTE 3	1	MBO9AAJ01A

DIMENSIONS ARE IN MILLIMETERS
 UNLESS OTHERWISE SPECIFIED
 TOLERANCES
 0.5-6 = ±0.2
 6-30 = ±0.4
 30-120 = ±0.6
 120-315 = ±1
 315-1000 = ±1.6
 1000-2000 = ±2.4

PART NO.	
APPROVED	DATE
CHECKED	DATE
DRAWN	DATE

gawcky
Ken
Ken

Amphenol	
Danbury,CT,USA-Tainan,Taiwan-Shenzhen,China	
TITLE MMCX REVERSE POLARITY R/A CRIMP PLUG (FOR RG-174/U,188A/U,316/U)	
DRAWING NO. RMMCX1112A1-3GT30G-316U-50	
ITEM NO. 591112AAA36GE5F	

NO.	DESCRIPTION	MATERIAL	FINISH	Q'TY	DRAWING NO.	SCALE	6/1	ISSUE	A	FILE NO.
										F:\DWG\RMMCX\1112A1\316U-50\3GT30G

1 2 3 4 5 6 7RD-DR 1697 8