

REVISIONS		
ISS	ZONE	DESCRIPTION\PER REQUEST\DATE

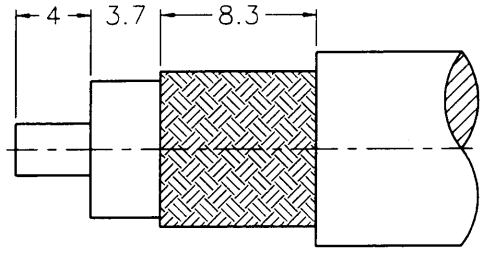

RECOMMENDED
CABLE STRIPPING DIM'S
(建議剝線尺寸)

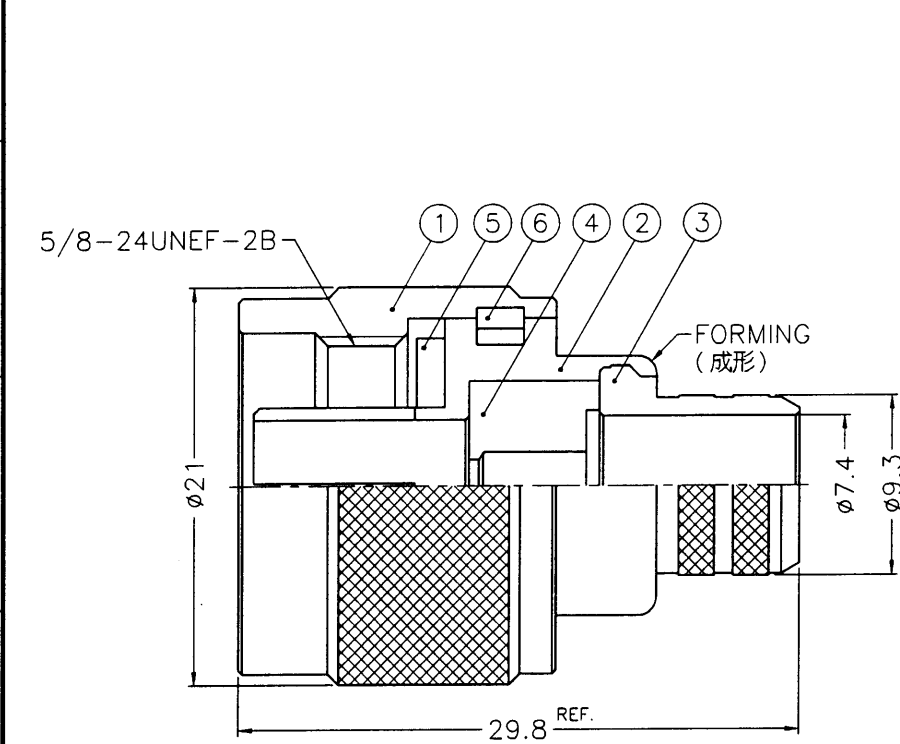
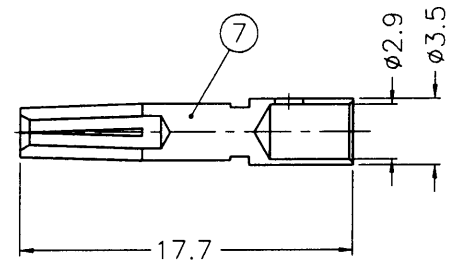

業務部

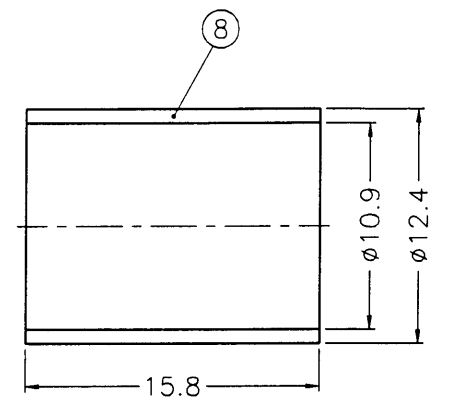

- NOTES: FINISH (PLATING THICKNESS IN MICRO-INCHES)
1. BRASS PER QQ-B-626
 2. NICKEL PL. 100 MIN. THICK OVER COPPER STRIKE
 3. PHOSPHOR BRONZE PER QQ-B-750
 4. GOLD PL. 3 MIN. THICK OVER NICKEL PL. 100 MIN. THICK OVER COPPER STRIKE
 5. TEFLON MIL-P-19468
 6. JIS H 3250, C 2700

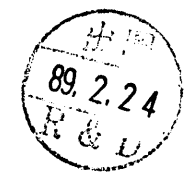

1. CRIMPED FERRULE
HEX CRIMP SIZE .429"
2. CRIMPED CONTACT PIN
HEX CRIMP SIZE .118"

NO.	DESCRIPTION	MATERIAL	FINISH	Q'TY	DRAWING NO.
8	FERRULE	NOTE 6	NOTE 2	1	FR-124/109X158
7	CONTACT PIN	NOTE 3	NOTE 4	1	RN1121A1-8-35/29
6	RETAINER RING	SUS 304	NATURAL	1	N5000-7-C
5	GASKET	SILICONE	RED	1	GS-156/8X15
4	INSULATOR	NOTE 5	NATURAL	1	N5201-5T-50-9913
3	BARREL	NOTE 1	NOTE 2	1	N5000-3-93/74
2	BODY	NOTE 1	NOTE 2	1	N1121A2-2
1	SHELL	NOTE 1	NOTE 2	1	N5000-1-B

DIMENSIONS ARE IN MILLIMETERS
UNLESS OTHERWISE SPECIFIED TOLERANCES

0.5-6 = ±0.2
6-30 = ±0.4
30-120 = ±0.6
120-315 = ±1
315-1000 = ±1.6
1000-2000 = ±2.4

PART NO.	
APPROVED	DATE 02-21-00'
CHECKED	DATE 02-21-00'
DRAWN	DATE 02-21-00'

Amphenol - Kai Jack	
TAINAN TAIWAN	
TITLE	N REVERSE POLARITY CRIMP PLUG (FOR BELDEN 9913, 9914)
DRAWING NO.	KJ-RN1121A2-NT3G-9913-50
FILE NO.	F:\DWG\RN\1121A2\9913-50\NT3G