

REVISIONS			
ISS	ZONE	DESCRIPTION\PER REQUEST\DATE	
C	A-1	NO.1 WAS CHANGED\RD-DM89042001C\04-20-00'	
	D-3	DRAWING WAS CHANGED\N/A\12-09-02'	

SALES

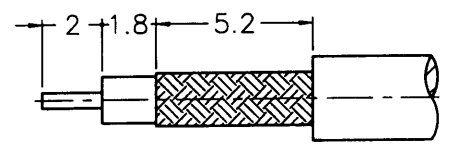

RECOMMENDED
CABLE STRIPPING DIM'S
(建議剝線尺寸)

STAKE IN 4 PLACES
EQUALLY SPACED 90°
APART
(打四點 間隔 90°)

1/4-36UNS-2B

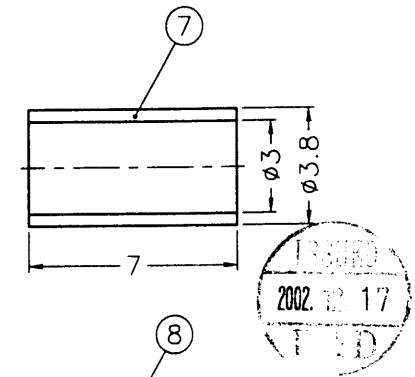
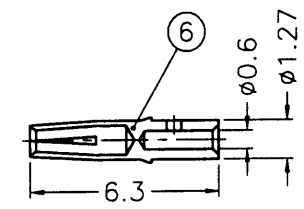
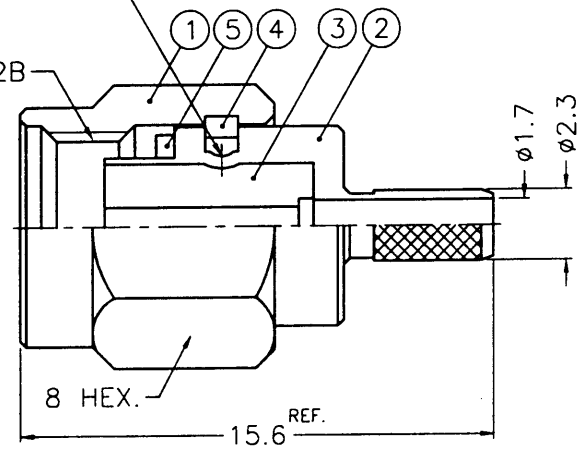

1. CRIMPED FERRULE
HEX. CRIMP SIZE .128"
2. CONTACT PIN TO SOLDER

NOTES: FINISH (PLATING THICKNESS IN MICRO-INCHES)

1. BRASS PER QQ-8-626
2. GOLD PL. 3 MIN. THICK OVER NICKEL PL. 100 MIN. THICK OVER COPPER STRIKE
3. BERYLLIUM COPPER PER QQ-C-530
4. GOLD PL. 50 MIN. THICK OVER NICKEL PL. 100 MIN. THICK OVER COPPER STRIKE
5. TEFLON MIL-P-19468

NO.	DESCRIPTION	MATERIAL	FINISH	Q'TY	DRAWING NO.
8	HEAT SHRINK TUBING		BLACK	1	HT-56/5X193
7	FERRULE	COPPER	NOTE 2	1	FR-38/3X7C
6	CONTACT PIN	NOTE 3	NOTE 4	1	SMA87051902-3
5	GASKET	SILICONE	RED	1	GS-6/43X06
4	RETAINER RING	NOTE 3	NATURAL	1	SMA5000-4-B
3	INSULATOR	NOTE 5	NATURAL	1	RSMA1111A2-3T-50
2	BODY	NOTE 1	NOTE 2	1	RSMA1111A2-2-23/17
1	SHELL	NOTE 1	NOTE 2	1	SMA5000-1-C

DIMENSIONS ARE IN MILLIMETERS				PART NO.	
UNLESS OTHERWISE SPECIFIED TOLERANCES 0.5-6 = ±0.2 6-30 = ±0.4 30-120 = ±0.6 120-315 = ±1 315-1000 = ±1.6 1000-2000 = ±2.4				APPROVED	DATE
				CHECKED	DATE
				DRAWN	DATE
				FILE NO.	

Amphenol	
Danbury,CT,USA-Tainan,Taiwan-Shenzhen,China	
TITLE	SMA REVERSE POLARITY CRIMP PLUG
DRAWING NO.	RSMA1111A2-3GT50G-316U-50
ITEM NO.	611111AAB36GA5F

F
E
D
C
B
A

F
E
D
C
B
A