

REVISIONS		
ISS	ZONE	DESCRIPTION\APPROVED\DATE

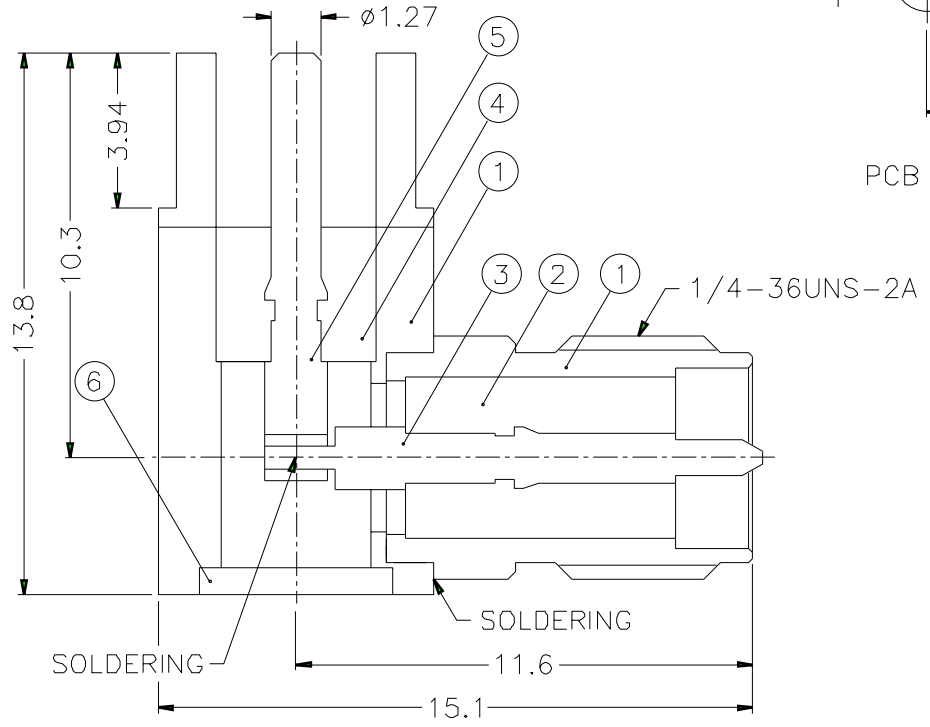
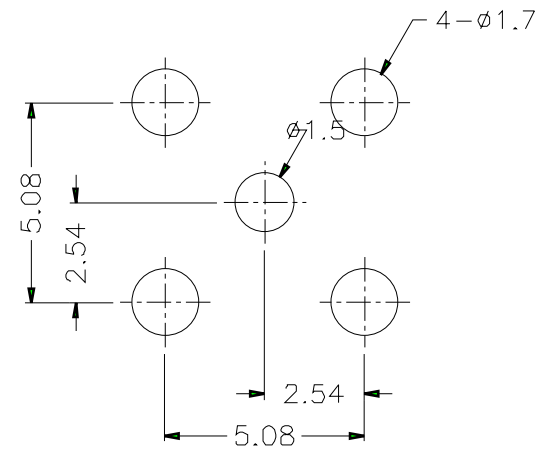
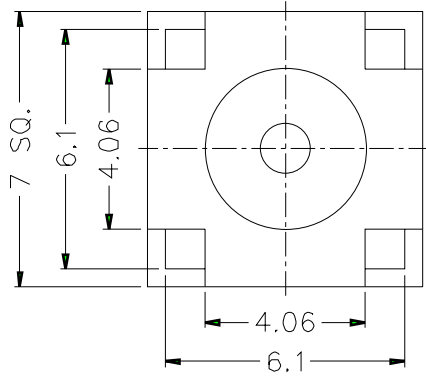

NOTES: FINISH (PLATING THICKNESS IN MICRO-INCHES)
 1. BRASS PER QQ-B-626
 2. GOLD PL. 3 MIN. THICK OVER NICKEL PL. 100 MIN. THICK OVER COPPER STRIKE
 3. GOLD PL. 50 MIN. THICK OVER NICKEL PL. 100 MIN. THICK OVER COPPER STRIKE
 4. TEFLON MIL-P-19468

NO.	DESCRIPTION	MATERIAL	FINISH	Q'TY	DRAWING NO.
6	COVER	NOTE 1	NOTE 2	1	CV-5X05-T
5	CONTACT PIN	NOTE 1	NOTE 3	1	RSMA6252A2-5
4	INSULATOR	NOTE 4	NATURAL	1	SMA7790-5T-50
3	CONTACT PIN	NOTE 1	NOTE 3	1	RSMA6252A2-3
2	INSULATOR	NOTE 4	NATURAL	1	SMA6252A2-3T-50-B
1	HOUSING WITH BODY	NOTE 1	NOTE 3	1	RSMA6252A2-1S

DIMENSIONS ARE IN MILLIMETERS			
UNLESS OTHERWISE SPECIFIED TOLERANCES			
0.5-6	=	±0.2	
6-30	=	±0.4	
30-120	=	±0.6	
120-315	=	±1	
315-1000	=	±1.6	
1000-2000	=	±2.4	

PART NO.	
APPROVED	DATE
CHECKED	DATE
DRAWN	DATE

Amphenol - Kai Jack	
TAINAN TAIWAN	
TITLE	SMA REVERSE POLARITY R/A P.C. MOUNT JACK
DRAWING NO.	KJ-RSMA6252A2-3GT50G-50
FILE NO.	F:\DWG\RSMA\6252A2\50\3GT50G