

1 2 3 4 5 6 7 8

REVISIONS			
ISS	ZONE	DESCRIPTION	PER REQUEST DATE
A1	A-3	NO.4 WAS CHANGED	RD-DM91052301K\05-28-02'

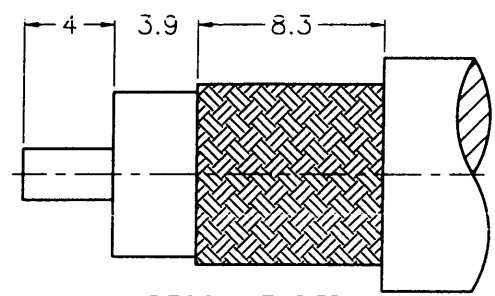

SALES

RECOMMENDED
CABLE STRIPPING DIM'S
(建議剝線尺寸)

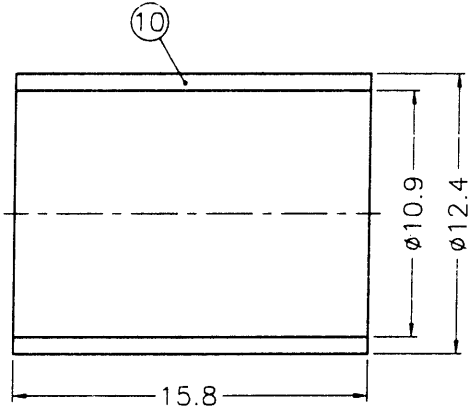
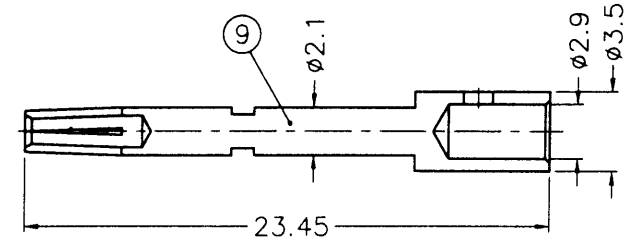

ISSUED
2002. 5. 30
R&D

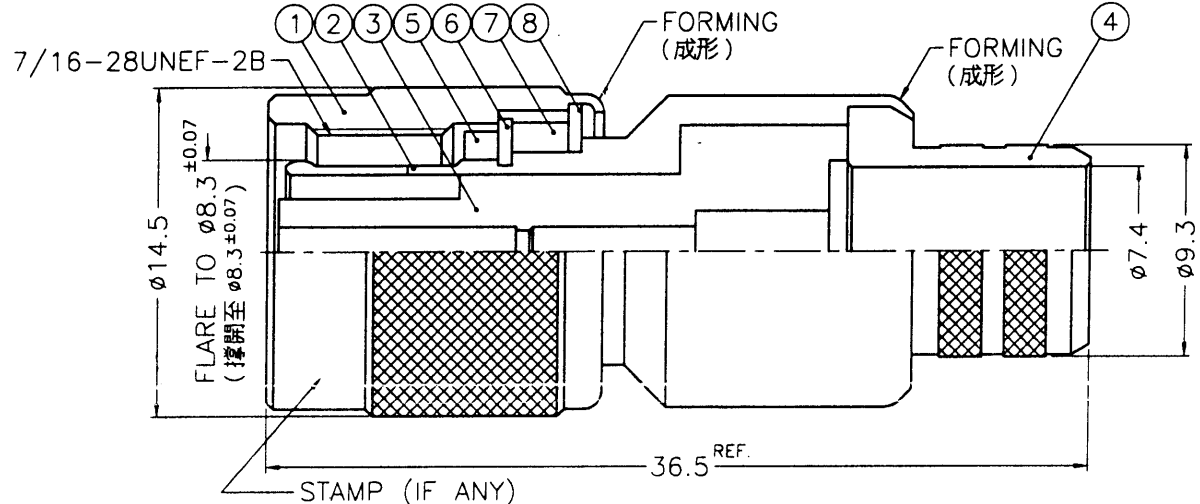

- NOTES: FINISH (PLATING THICKNESS IN MICRO-INCHES)
1. BRASS PER QQ-B-626
 2. BRASS PER QQ-B-613
 3. NICKEL PL. 100 MIN. THICK OVER COPPER STRIKE
 4. PHOSPHOR BRONZE PER QQ-B-750
 5. GOLD PL. 3 MIN. THICK OVER NICKEL PL. 100 MIN. THICK OVER COPPER STRIKE
 6. TEFLON MIL-P-19468
 7. JIS H 3250, C 2600

1. CRIMPED FERRULE
HEX CRIMP SIZE .429"
2. CONTACT PIN TO SOLDER

10	FERRULE	NOTE 7	NOTE 3	1	FR-124/109X158
9	CONTACT PIN	NOTE 4	NOTE 5	1	RT1121A6-9-35/29
8	WASHER	NOTE 2	NOTE 3	1	WS-128/9X08
7	RING	DELIN	NATURAL	1	T50000-6-A
6	RETAINER RING	NOTE 1	NOTE 3	1	B50000-5
5	GASKET	RUBBER	RED	1	GS-105/8X15
4	BARREL	NOTE 1	NOTE 3	1	N5000-3-93/74-B
3	INSULATOR	NOTE 6	NATURAL	1	RT1121A6-3T-50
2	BODY	NOTE 1	NOTE 3	1	RT1121A6-2
1	SHELL	NOTE 1	NOTE 3	1	T50000-1-B

DIMENSIONS ARE IN MILLIMETERS				PART NO.	
UNLESS OTHERWISE SPECIFIED TOLERANCES				APPROVED	DATE
0.5-6 = ±0.2				<i>A. Park</i>	05-28-02'
6-30 = ±0.4				CHECKED	DATE
30-120 = ±0.6				<i>Karl Y.</i>	05-28-02'
120-315 = ±1				DRAWN	DATE
315-1000 = ±1.6				<i>Angela W.</i>	05-28-02'
1000-2000 = ±2.4				FILE NO.	F:\DWG\RT\1121A6\9913-50\NT3G

Amphenol - Kai Jack	
TAINAN TAIWAN	TITLE TNC REVERSE POLARITY CRIMP PLUG (FOR BELDEN 8214, 9913)
DRAWING NO. KJ-RT1121A6-NT3G-9913-50	ITEM NO. 521121AAB93NA5F

F
E
D
C
B
A

F
E
D
C
B
A

1 2 3 4 5 6

7RD-DR/45708