

REVISIONS		
ISS	ZONE	DESCRIPTION\PER REQUEST\DATE

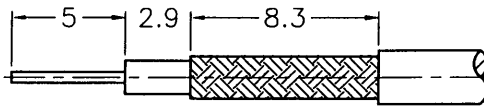

RECOMMENDED
CABLE STRIPPING DIM'S
(建議剝線尺寸)

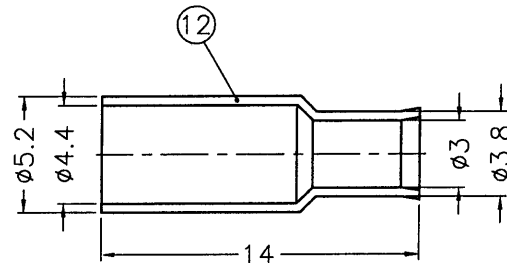
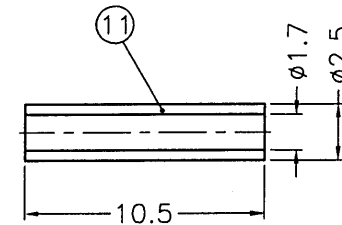
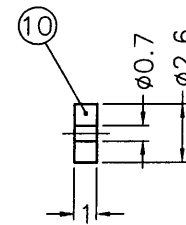
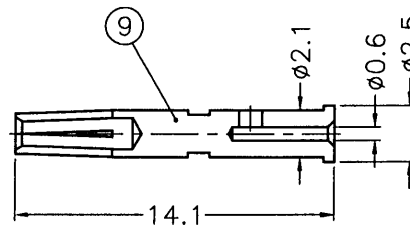
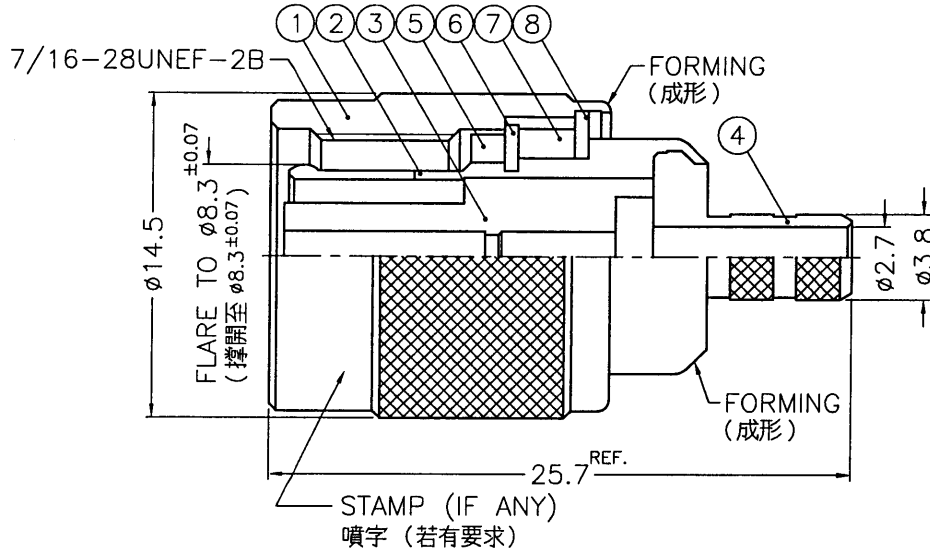

- NOTES: FINISH (PLATING THICKNESS IN MICRO-INCHES)
- BRASS PER QQ-B-626
 - BRASS PER QQ-B-613
 - NICKEL PL. 100 MIN. THICK OVER COPPER STRIKE
 - GOLD PL. 3 MIN. THICK OVER NICKEL PL. 100 MIN. THICK OVER COPPER STRIKE
 - TEFLON MIL-P-19468
 - JIS H 3250, C 2600



- CRIMPED FERRULE
HEX CRIMP SIZE .178"
- CRIMPED CONTACT PIN
HEX CRIMP SIZE .068"

12	FERRULE	NOTE 6	NOTE 3	1	FR-52/44-38/3X14
11	SLEEVE	NOTE 1	NOTE 3	1	SL00AAK---
10	INSULATOR	NOTE 5	NATURAL	1	NS00AGM34A
9	CONTACT PIN	NOTE 1	NOTE 4	1	B74000-8-25/06
8	WASHER	NOTE 2	NOTE 3	1	WS-128/9X08
7	RING	DELFIN	NATURAL	1	T50000-6-A
6	RETAINER RING	NOTE 1	NOTE 3	1	B50000-5
5	GASKET	RUBBER	RED	1	GS-105/8X15
4	BARREL	NOTE 1	NOTE 3	1	B50900-6-38/27S
3	INSULATOR	NOTE 5	NATURAL	1	RB1121A1-3T-50
2	BODY	NOTE 1	NOTE 3	1	RB1121A1-2
1	SHELL	NOTE 1	NOTE 3	1	T50000-1-B
NO.	DESCRIPTION	MATERIAL	FINISH	Q'TY	DRAWING NO.

DIMENSIONS ARE IN MILLIMETERS
UNLESS OTHERWISE SPECIFIED
TOLERANCES
0.5-6 = ±0.2
6-30 = ±0.4
30-120 = ±0.6
120-315 = ±1
315-1000 = ±1.6
1000-2000 = ±2.4

PART NO.	
APPROVED	DATE 07-22-04'
CHECKED	DATE 07-22-04'
DRAWN	DATE 07-22-04'
FILE NO.	F:\DWG\RT\1121E1\004\50\NT3G

Amphenol	
Danbury,CT,USA-Tainan,Taiwan-Shenzhen,China	
TITLE	TNC REVERSE POLARITY CRIMP PLUG (FOR RG-174/U,188A/U,316/U)
DRAWING NO.	RT1121E1-004-NT3G-50
ITEM NO.	521121AAV36NA5F