

REVISIONS		
ISS	ZONE	DESCRIPTION\PER REQUEST\DATE

業務部

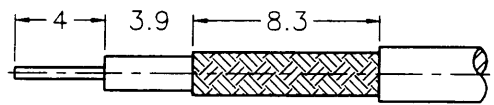

RECOMMENDED  
CABLE STRIPPING DIM'S  
(建議剝線尺寸)

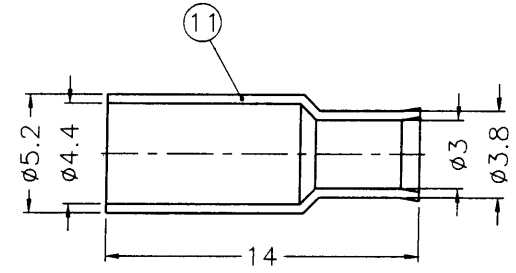
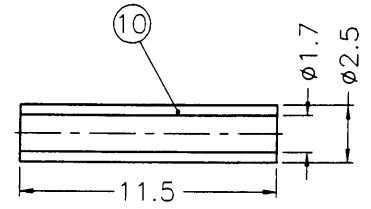
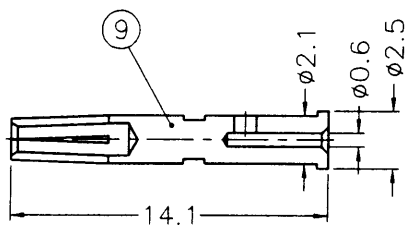
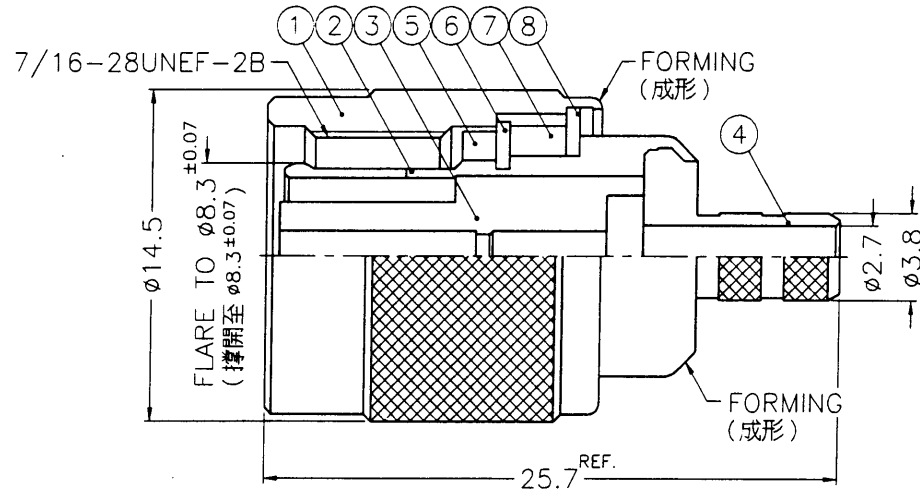

- NOTES: FINISH (PLATING THICKNESS IN MICRO-INCHES)
1. BRASS PER QQ-B-626
  2. BRASS PER QQ-B-613
  3. NICKEL PL. 100 MIN. THICK OVER COPPER STRIKE
  4. GOLD PL. 3 MIN. THICK OVER NICKEL PL. 100 MIN. THICK OVER COPPER STRIKE
  5. TEFLON MIL-P-19468
  6. JIS H 3260, C 3501

出圖  
2000. 11. 04

1. CRIMPED FERRULE  
HEX CRIMP SIZE .178"
2. CRIMPED CONTACT PIN  
HEX CRIMP SIZE .068"

11	FERRULE	NOTE 6	NOTE 3	1	FR-52/44-38/3X14
10	SLEEVE	DELRIN	NATURAL	1	SL-25/17X115
9	CONTACT PIN	NOTE 1	NOTE 4	1	B74000-8-25/06
8	WASHER	NOTE 2	NOTE 3	1	WS-128/9X08
7	RING	DELRIN	NATURAL	1	T50000-6-A
6	RETAINER RING	NOTE 1	NOTE 3	1	B50000-5
5	GASKET	RUBBER	RED	1	GS-105/8X15
4	BARREL	NOTE 1	NOTE 3	1	B50900-6-38/27S
3	INSULATOR	NOTE 5	NATURAL	1	RB1121A1-3T-50
2	BODY	NOTE 1	NOTE 3	1	RB1121A1-2
1	SHELL	NOTE 1	NOTE 3	1	T50000-1-B
NO.	DESCRIPTION	MATERIAL	FINISH	Q'TY	DRAWING NO.

DIMENSIONS ARE IN MILLIMETERS				PART NO.	
UNLESS OTHERWISE SPECIFIED TOLERANCES				APPROVED	DATE
0.5-6	= ±0.2			<i>Ask C</i>	11-03-00'
6-30	= ±0.4			CHECKED	DATE
30-120	= ±0.6			<i>Jacky</i>	11-03-00'
120-315	= ±1			DRAWN	DATE
315-1000	= ±1.6			<i>Ada</i>	11-03-00'
1000-2000	= ±2.4				
SCALE	3/1	ISSUE	A		

Amphenol - Kai Jack	
TAINAN TAIWAN	
TITLE	TNC REVERSE POLARITY CRIMP PLUG (FOR RG-174/U, 188A/U, 316/U)
DRAWING NO.	KJ-RT1121E1-NT3G-316U-50
FILE NO.	F:\DWG\RT\1121E1\316U-50\NT3G

F  
E  
D  
C  
B  
A