

REVISIONS		
ISS	ZONE	DESCRIPTION\PER REQUEST\DATE
A1	A-1	NO.6 WAS CHANGED\N/A\01-23-03'

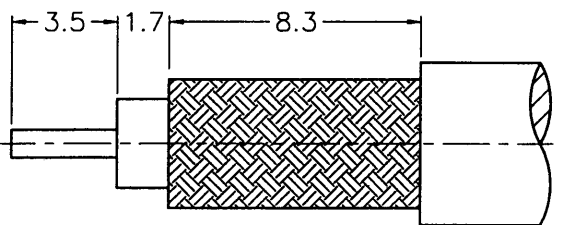

RECOMMENDED
CABLE STRIPPING DIM'S
(建議剝線尺寸)

SALES

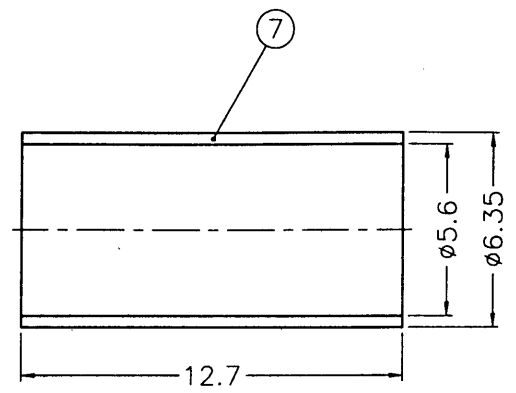
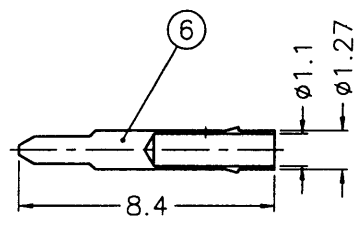
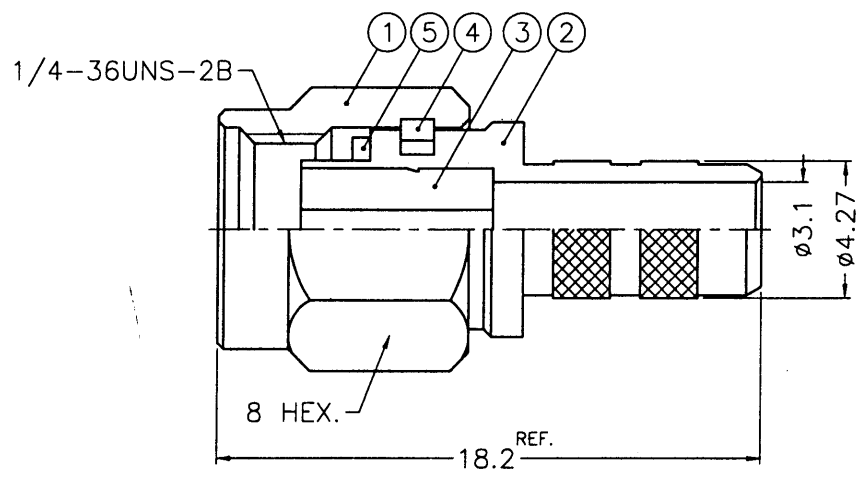

ISSUED
2003. 2. 10
R & D

- NOTES: FINISH (PLATING THICKNESS IN MICRO-INCHES)
1. BRASS PER QQ-B-626
 2. GOLD PL. 3 MIN. THICK OVER NICKEL PL. 100 MIN. THICK OVER COPPER STRIKE
 3. BERYLLIUM COPPER PER QQ-C-530
 4. GOLD PL. 50 MIN. THICK OVER NICKEL PL. 100 MIN. THICK OVER COPPER STRIKE
 5. TEFLON MIL-P-19468
 6. JIS H 3250, C 2600

1. CRIMPED FERRULE
HEX. CRIMP SIZE .213"
2. CONTACT PIN TO SOLDER

NO.	DESCRIPTION	MATERIAL	FINISH	Q'TY	DRAWING NO.
7	FERRULE	NOTE 6	NOTE 2	1	FR-635/56X127
6	CONTACT PIN	NOTE 1	NOTE 4	1	SMA5000-6-127/11
5	GASKET	SILICONE	RED	1	GS-6/43X06
4	RETAINER RING	NOTE 3	NATURAL	1	SMA5000-4-B
3	INSULATOR	NOTE 5	NATURAL	1	SMA5000-3T-50
2	BODY	NOTE 1	NOTE 2	1	SMA5000-2-427/31
1	SHELL	NOTE 1	NOTE 2	1	SMA5000-1-C

DIMENSIONS ARE IN MILLIMETERS
UNLESS OTHERWISE SPECIFIED TOLERANCES

0.5-6	= ±0.2
6-30	= ±0.4
30-120	= ±0.6
120-315	= ±1
315-1000	= ±1.6
1000-2000	= ±2.4

PART NO.	
APPROVED	<i>gackey</i> DATE 01-23-03'
CHECKED	<i>Ken</i> DATE 01-23-03'
DRAWN	<i>Ken</i> DATE 01-23-03'
FILE NO.	F:\DWG\SMA\1111A1\223U-50\3GT50G

Amphenol	
Danbury, CT, USA - Tainan, Taiwan - Shenzhen, China	
TITLE	SMA CRIMP PLUG (FOR RG-55/U, 142A/U, 223/U, 400/U)
DRAWING NO.	SMA1111A1-3GT50G-223U-50
ITEM NO.	111111AAA26GA5F

A