

業務部

REVISIONS		
ISS	ZONE	DESCRIPTION\PER REQUEST\DATE
B	A-1	NO.1 WAS CHANGED\RD-DM89042001C\04-20-00'

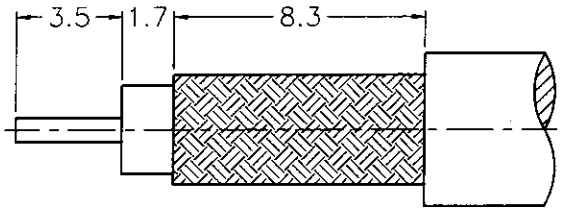

RECOMMENDED
CABLE STRIPPING DIM'S
(建議剝線尺寸)

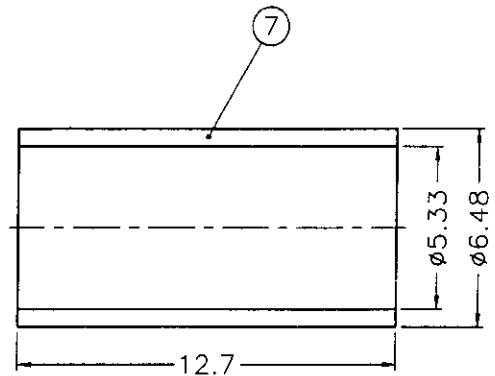
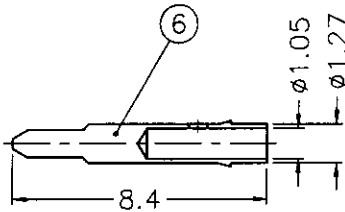
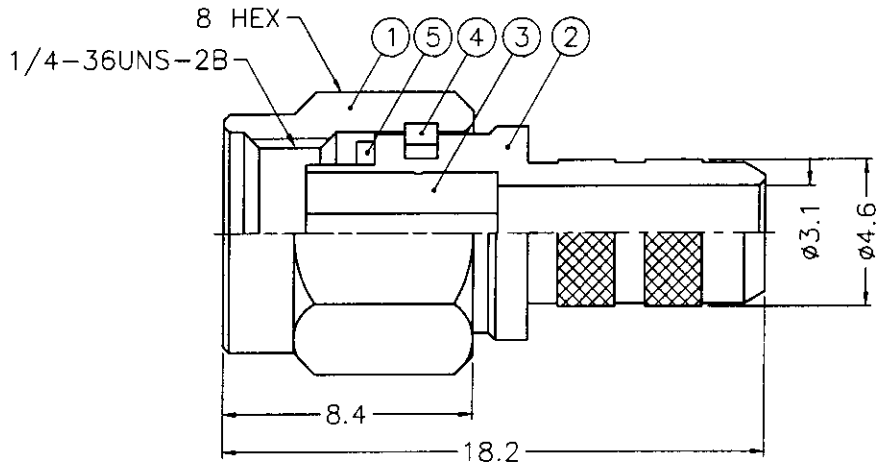

NOTES: FINISH (PLATING THICKNESS IN MICRO-INCHES)

1. BRASS PER QQ-B-626
2. NICKEL PL. 100 MIN. THICK OVER COPPER STRIKE
3. BERYLLIUM COPPER PER QQ-C-530
4. GOLD PL. 50 MIN. THICK OVER NICKEL PL. 100 MIN. THICK OVER COPPER STRIKE
5. TEFLON MIL-P-19468



1. CRIMPED FERRULE
HEX CRIMP SIZE .213"

NO.	DESCRIPTION	MATERIAL	FINISH	Q'TY	DRAWING NO.
7	FERRULE	COPPER	NOTE 2	1	FR-648/533X 127C
6	CONTACT PIN	NOTE 1	NOTE 4	1	SMA5000-6-127/105
5	GASKET	SILICONE	RED	1	GS-6/43X06
4	RETAINER RING	NOTE 3	NATURAL	1	SMA5000-4-B
3	INSULATOR	NOTE 5	NATURAL	1	SMA5000-3T-50
2	BODY	NOTE 1	NOTE 2	1	SMA5000-2-46/31-C
1	SHELL	NOTE 1	NOTE 2	1	SMA5000-1-C

DIMENSIONS ARE IN MILLIMETERS
UNLESS OTHERWISE SPECIFIED TOLERANCES
0.5-6 = ±0.2
6-30 = ±0.4
30-120 = ±0.6
120-315 = ±1
315-1000 = ±1.6
1000-2000 = ±2.4

PART NO.		DATE	
APPROVED	<i>Andy.C</i>	DATE	04-27-00'
CHECKED	<i>Andy.C</i>	DATE	04-27-00'
DRAWN	<i>Joyce.Y</i>	DATE	04-27-00'

Amphenol - Kai Jack
TAINAN TAIWAN

TITLE	
SMA CRIMP PLUG (FOR RG-58C/U, 58/U)	
DRAWING NO.	
KJ-SMA1111A1-NT50G-58U-50	
FILE NO.	
F:\DWG\SMA\1111A1\58U-50\NT50G	

8/2/2