

REVISIONS

ISS	ZONE	DESCRIPTION\PER REQUEST\DATE

SALES

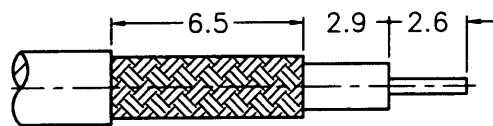

RECOMMENDED  
CABLE STRIPPING DIM'S  
(建議剝線尺寸)

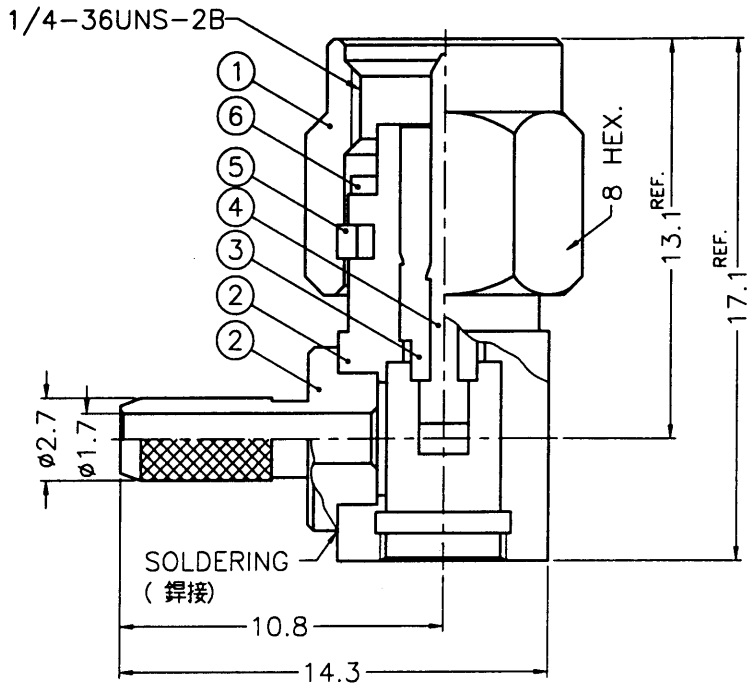
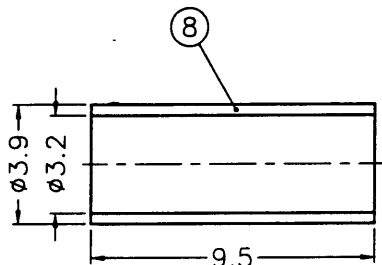

NOTES: FINISH (PLATING THICKNESS IN MICRO-INCHES)

- BRASS PER QQ-B-626
- GOLD PL. 3 MIN. THICK OVER NICKEL PL. 100 MIN. THICK OVER COPPER STRIKE
- BERYLLIUM COPPER PER QQ-C-530
- GOLD PL. 30 MIN. THICK OVER NICKEL PL. 100 MIN. THICK OVER COPPER STRIKE
- TEFLON MIL-P-19468
- JIS H 3250, C 2600

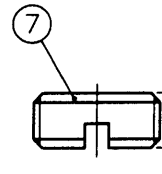
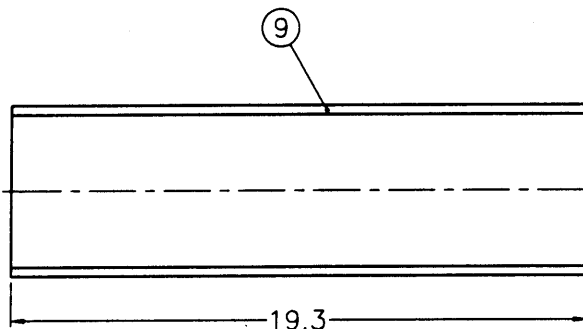

ISSUED  
2002. 8. 29  
R & D

- CRIMPED FERRULE HEX. CRIMP SIZE .128"
- CONTACT PIN TO SOLDER

9	HEAT SHRINK TUBING		BLACK	1	HT-56/5X193
8	FERRULE	NOTE 6	NOTE 2	1	FR-39/32X95
7	COVER	NOTE 1	NOTE 2	1	SMA1112A3-8-B
6	GASKET	SILICONE	RED	1	GS-6/43X06
5	RETAINER RING	NOTE 3	NATURAL	1	SMA5000-4-B
4	CONTACT PIN	NOTE 1	NOTE 4	1	SMA1112A4-4-B
3	INSULATOR	NOTE 5	NATURAL	1	SMA1112A3-3T-50
2	HOUSING	NOTE 1	NOTE 2	1	SMA1112A3-2S-27/17
1	SHELL	NOTE 1	NOTE 2	1	SMA5000-1-C
NO.	DESCRIPTION	MATERIAL	FINISH	Q'TY	DRAWING NO.

DIMENSIONS ARE IN MILLIMETERS			PART NO.	
UNLESS OTHERWISE SPECIFIED TOLERANCES			APPROVED	DATE
0.5-6	= ±0.2		<i>Jacky</i>	08-23-02'
6-30	= ±0.4		<i>Jacky</i>	08-23-02'
30-120	= ±0.6		<i>Jacky</i>	08-23-02'
120-315	= ±1			
315-1000	= ±1.6			
1000-2000	= ±2.4			
SCALE	4/1	ISSUE	A	FILE NO. F:\DWG\SMA1112A3\316U-50\3GT30G

Amphenol - Kai Jack	
TAINAN TAIWAN	
TITLE	SMA R/A CRIMP PLUG (FOR RG-174/U, 188A/U, 316/U)
DRAWING NO.	KJ-SMA1112A3-3GT30G-316U-50
ITEM NO.	111112AAB36GE5F

7RD-02/534/8