

業務部

REVISIONS		
ISS	ZONE	DESCRIPTION\APPROVED\DATE
B	A-1	NO.1 WAS CHANGED\RD-DM89042001C\04-20-00'

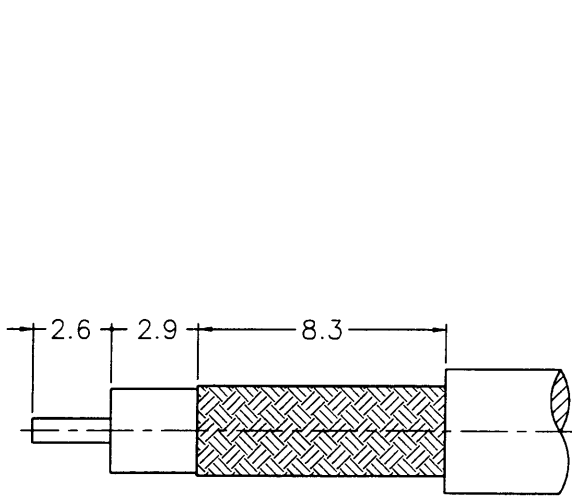

RECOMMENDED
CABLE STRIPPING DIM'S
(建議剝線尺寸)

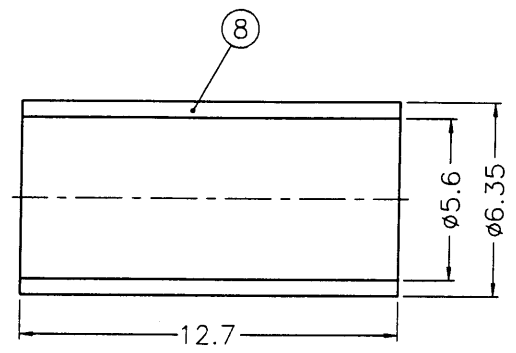
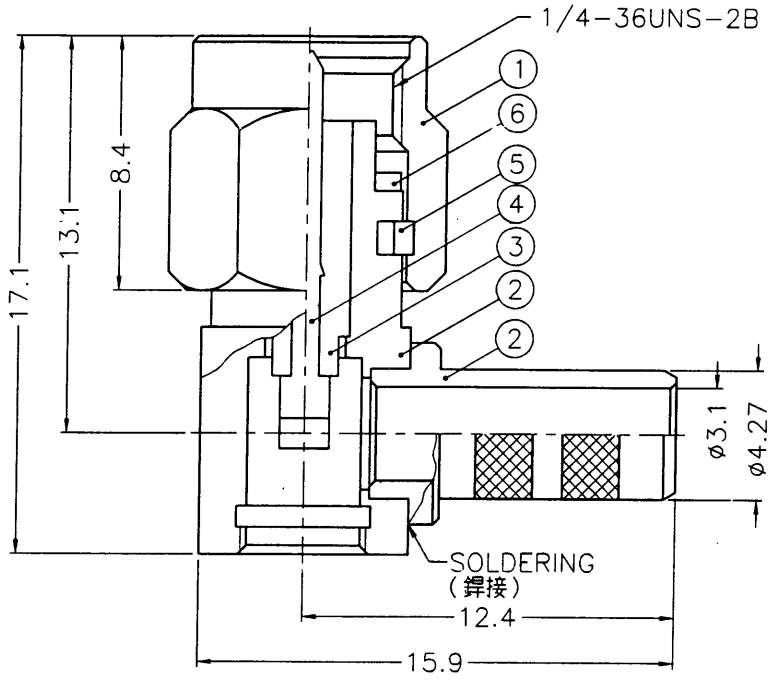

- NOTES: FINISH (PLATING THICKNESS IN MICRO-INCHES)
- BRASS PER QQ-B-626
 - GOLD PL. 3 MIN. THICK OVER NICKEL PL. 100 MIN. THICK OVER COPPER STRIKE
 - BERYLLIUM COPPER PER QQ-C-530
 - GOLD PL. 50 MIN. THICK OVER NICKEL PL. 100 MIN. THICK OVER COPPER STRIKE
 - TEFLON MIL-P-19468
 - JIS H 3250, C 2700

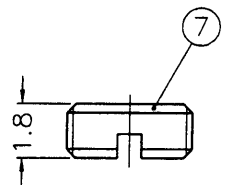

89.5.03
設計部

1. CRIMPED FERRULE
HEX CRIMP SIZE .213"

NO.	DESCRIPTION	MATERIAL	FINISH	Q'TY	DRAWING NO.
8	FERRULE		NOTE 6	NOTE 2	1 FR-635/56X127
7	COVER		NOTE 1	NOTE 2	1 SMA1112A3-8-B
6	GASKET	SILICONE	RED		1 GS-6/43X06
5	RETAINER RING		NOTE 3	NATURAL	1 SMA5000-4-B
4	CONTACT PIN		NOTE 1	NOTE 4	1 SMA1112A4-4-B
3	INSULATOR		NOTE 5	NATURAL	1 SMA1112A3-3T-50
2	HOUSING WITH BARREL		NOTE 1	NOTE 2	1 SMA1112A4-2S-427/31
1	SHELL		NOTE 1	NOTE 2	1 SMA5000-1-C

DIMENSIONS ARE IN MILLIMETERS
UNLESS OTHERWISE SPECIFIED TOLERANCES

0.5-6	= ±0.2
6-30	= ±0.4
30-120	= ±0.6
120-315	= ±1
315-1000	= ±1.6
1000-2000	= ±2.4

PART NO.	
APPROVED	DATE
CHECKED	DATE
DRAWN	DATE

Amphenol - Kai Jack	
TAINAN TAIWAN	
TITLE SMA R/A CRIMP PLUG	
DRAWING NO. KJ-SMA1112A4-3GT50G-223U-50	
FILE NO. F:\DWG\SMA\1112A4\223U-50\3GT50G	