

REVISIONS		
ISS	ZONE	DESCRIPTION\PER REQUEST\DATE
B	A-2	SMA1181K1-3 WAS SMA5000-4-B\RD-DM88052101C \05-21-99'
C	A-1	NO.1 WAS CHANGED\RD-DM89042001C\04-20-00'

業務部

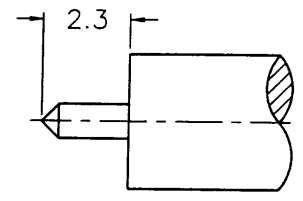

RECOMMENDED
CABLE STRIPPING DIM'S
(建議剝線尺寸)

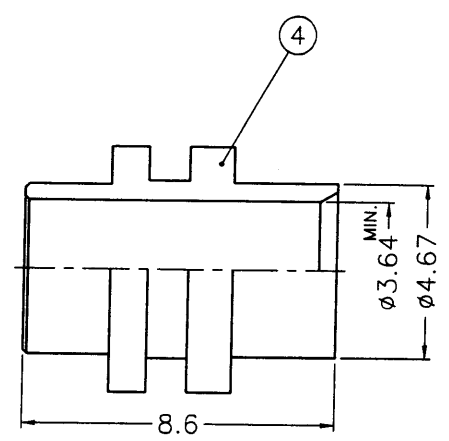
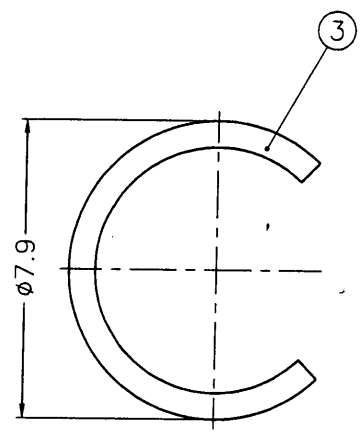
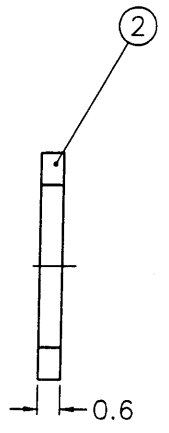
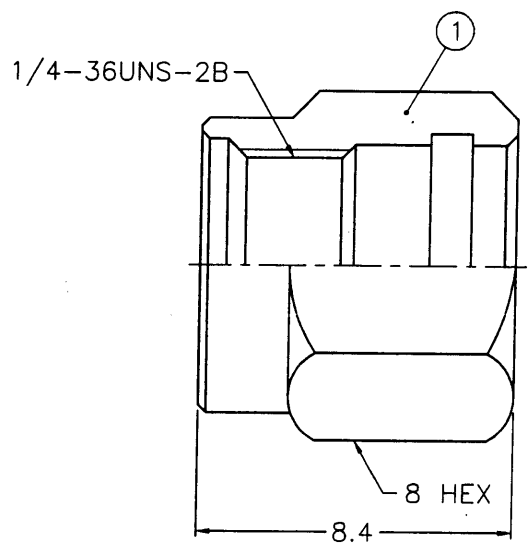

NOTES: FINISH (PLATING THICKNESS IN MICRO-INCHES)
 1. BRASS PER QQ-B-626
 2. BERYLLIUM COPPER PER QQ-C-530
 3. GOLD PL. 3 MIN. THICK OVER NICKEL PL. 100 MIN. THICK OVER COPPER STRIKE

89.5.24
設計部

					DIMENSIONS ARE IN MILLIMETERS				PART NO.		Amphenol - Kai Jack TAINAN TAIWAN			
					UNLESS OTHERWISE SPECIFIED TOLERANCES				APPROVED	DATE	TITLE			
4	BODY	NOTE 1	NOTE 3	1	SMA5080-4-A	0.5-6 = ±0.2	6-30 = ±0.4	30-120 = ±0.6	120-315 = ±1	315-1000 = ±1.6	1000-2000 = ±2.4	<i>Andy C</i>	05-23-00'	SMA DIRECT SOLDER PLUG
3	RETAINER RING	NOTE 2	NATURAL	1	SMA1181K1-3							<i>Andy C</i>	05-23-00'	DRAWING NO.
2	GASKET	SILICONE	RED	1	GS-6/43X06							<i>Irene L</i>	05-23-00'	KJ-SMA1181K1-3G-.141-50
1	SHELL	NOTE 1	NOTE 3	1	SMA5000-1-C									FILE NO. F:\DWG\SMA\1181K1\141-50\3G
NO.	DESCRIPTION	MATERIAL	FINISH	Q'TY	DRAWING NO.	SCALE	5/1	ISSUE	C					