

1 2 3 4 5 6 7 8

REVISIONS		
ISS	ZONE	DESCRIPTION\PER REQUEST\DATE

業務部

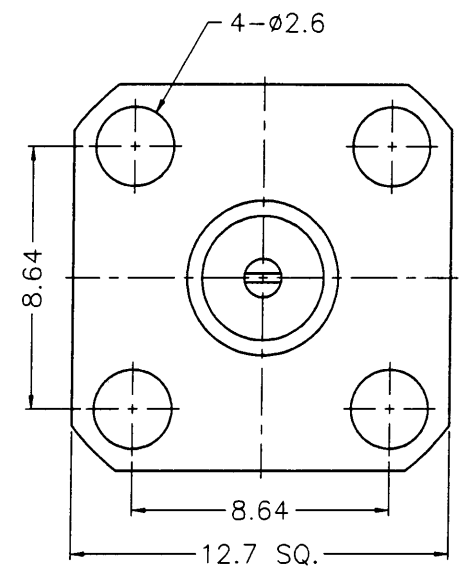
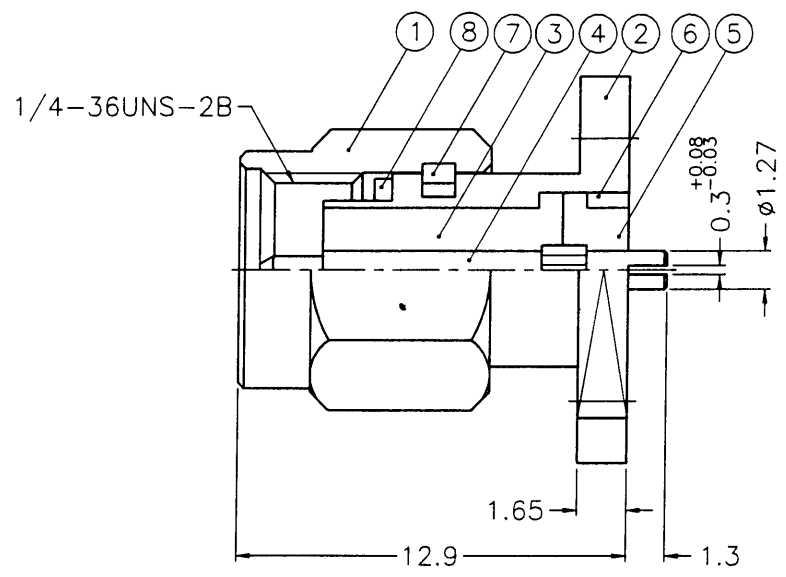

NOTES: FINISH (PLATING THICKNESS IN MICRO-INCHES)
 1. BRASS PER QQ-B-626
 2. GOLD PL. 3 MIN. THICK OVER NICKEL PL. 100 MIN. THICK OVER COPPER STRIKE
 3. BERYLLIUM COPPER PER QQ-C-530
 4. GOLD PL. 50 MIN. THICK OVER NICKEL PL. 100 MIN. THICK OVER COPPER STRIKE
 5. TEFLON MIL-P-19468



NO.	DESCRIPTION	MATERIAL	FINISH	Q'TY	DRAWING NO.
8	GASKET	SILICONE	RED	1	GS-6/43X06
7	RETAINER RING	NOTE 3	NATURAL	1	SMA5000-4-B
6	RING	NOTE 1	NOTE 2	1	SMA7530-5-B
5	INSULATOR	NOTE 5	NATURAL	1	SMA7530-4T-50
4	CONTACT PIN	NOTE 1	NOTE 4	1	SMA5540-4-0.35
3	INSULATOR	NOTE 5	NATURAL	1	SMA5530-3T-50-B
2	BODY	NOTE 1	NOTE 2	1	SMA5530-2-A
1	SHELL	NOTE 1	NOTE 2	1	SMA5000-1-C

DIMENSIONS ARE IN MILLIMETERS
 UNLESS OTHERWISE SPECIFIED TOLERANCES
 0.5-6 = ±0.2
 6-30 = ±0.4
 30-120 = ±0.6
 120-315 = ±1
 315-1000 = ±1.6
 1000-2000 = ±2.4

PART NO.	
APPROVED	DATE
CHECKED	DATE
DRAWN	DATE

Amphenol - Kai Jack	
TAINAN TAIWAN	
TITLE	SMA PANEL RECEPT. PLUG
DRAWING NO.	KJ-SMA1551C1-3GT50G-0.3-50
FILE NO.	F:\DWG\SMA\1551C1\03-50\3GT50G

F
E
D
C
B
A

F
E
D
C
E
A

1 2 3 4 5 6 7 8