

1 2 3 4 5 6 7 8

業務部

REVISIONS		
ISS	ZONE	DESCRIPTION\PER REQUEST\DATE

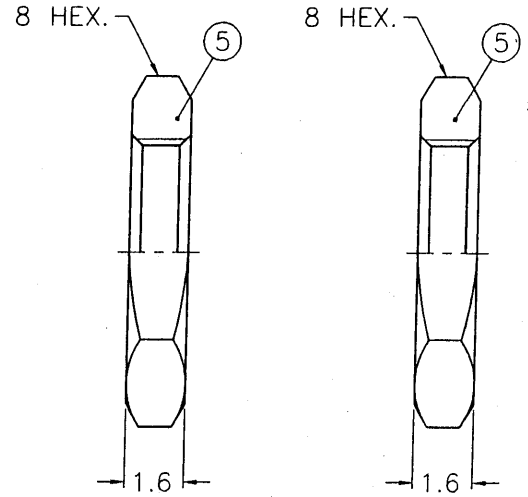
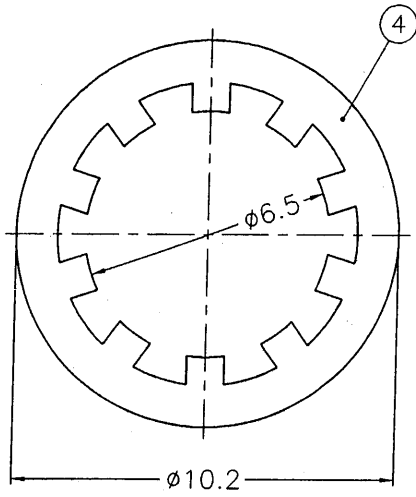
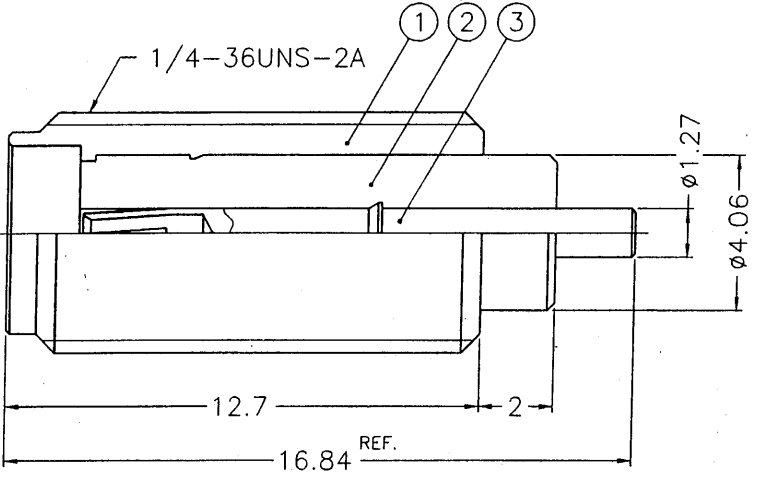

NOTES: FINISH (PLATING THICKNESS IN MICRO-INCHES)

1. BRASS PER QQ-B-626
2. BRASS PER QQ-B-613
3. GOLD PL. 3 MIN. THICK OVER NICKEL PL. 100 MIN. THICK OVER COPPER STRIKE
4. BERYLLIUM COPPER PER QQ-C-530
5. GOLD PL. 50 MIN. THICK OVER NICKEL PL. 100 MIN. THICK OVER COPPER STRIKE
6. TEFLON MIL-P-19468

出圖  
2001.2.06  
設計部

NO.	DESCRIPTION	MATERIAL	FINISH	Q'TY	DRAWING NO.	SCALE	5/1	ISSUE	A
5	HEX NUT	NOTE 1	NOTE 3	2	HN8-1/4-36X16	DIMENSIONS ARE IN MILLIMETERS UNLESS OTHERWISE SPECIFIED TOLERANCES 0.5-6 = ±0.2 6-30 = ±0.4 30-120 = ±0.6 120-315 = ±1 315-1000 = ±1.6 1000-2000 = ±2.4			
4	LOCK WASHER	NOTE 2	NOTE 3	1	LW-102/65X05				
3	CONTACT PIN	NOTE 4	NOTE 5	1	SMA6051A1-003-3				
2	INSULATOR	NOTE 6	NATURAL	1	SMA6051A1-003-2T-50				
1	BODY	NOTE 1	NOTE 3	1	SMA6051A1-003-1				
PART NO.						<b>Amphenol - Kai Jack</b> TAINAN TAIWAN			
APPROVED						TITLE SMA BULKHEAD RECEPT. JACK			
CHECKED						DRAWING NO. KJ-SMA6051A1-003-3GT50G-50			
DRAWN						FILE NO. F:\DWG\SMA\6051A1\003\50\3GT50G			

APPROVED: *Mark C* DATE: 02-05-01'  
 CHECKED: *Casey W* DATE: 02-05-01'  
 DRAWN: *Jeyp* DATE: 02-05-01'

DR20P11412