

REVISIONS		
ISS	ZONE	DESCRIPTION\PER REQUEST\DATE

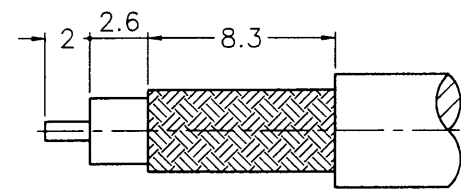

RECOMMENDED  
CABLE STRIPPING DIM'S  
(建議剝線尺寸)

業務部

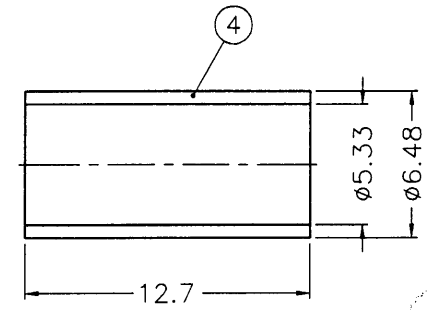
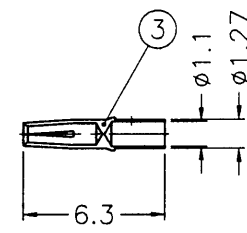
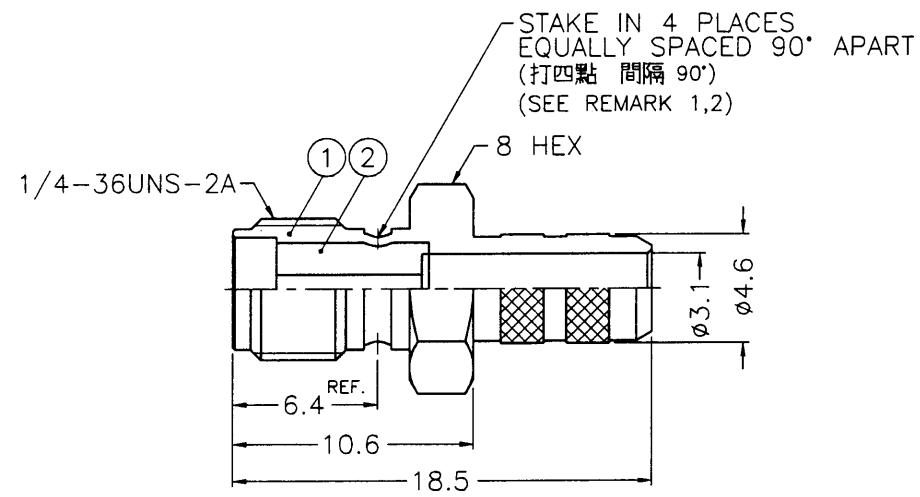

1. CRIMPED FERRULE  
HEX CRIMP SIZE .213"

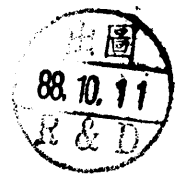

- NOTES: FINISH (PLATING THICKNESS IN MICRO-INCHES)
- BRASS PER QQ-B-626
  - GOLD PL. 3 MIN. THICK OVER NICKEL PL. 100 MIN. THICK OVER COPPER STRIKE
  - BERYLLIUM COPPER PER QQ-C-530
  - GOLD PL. 50 MIN. THICK OVER NICKEL PL. 100 MIN. THICK OVER COPPER STRIKE
  - TEFLON MIL-P-19468

- REMARK: 1. NO.2 MUST WITHSTAND A 6 lbs. MIN. PUSHOUT FORCE FROM NO.1 AFTER STAMPING OVER OPERATION
2. REMARK1 IS MAINTAINED BY STAMPING THE FOUR POINTS SHOWN ON THE DRAWING WITHOUT PUNCTURING NO.1
- (1. 打四點後零件2由零件1推出至少必須承受6磅推力)  
(2. 打四點後除需符合備註1要求外且不可擊穿零件1)

NO.	DESCRIPTION	MATERIAL	FINISH	Q'TY	DRAWING NO.	SCALE	3/1	ISSUE	A	PART NO.	TITLE		
4	FERRULE	COPPER	NOTE 2	1	FR-648/533X 127C	DIMENSIONS ARE IN MILLIMETERS UNLESS OTHERWISE SPECIFIED TOLERANCES 0.5-6 = ±0.2 6-30 = ±0.4 30-120 = ±0.6 120-315 = ±1 315-1000 = ±1.6 1000-2000 = ±2.4					<b>Amphenol - Kai Jack</b> TAINAN TAIWAN		
3	CONTACT PIN	NOTE 3	NOTE 4	1	SMA6511B3-3- 127/11		APPROVED	<i>Mark C</i>	DATE	10-07-99'		TITLE	SMA CRIMP JACK (FOR RG-58/U, 58C/U)
2	INSULATOR	NOTE 5	NATURAL	1	SMA6511B3-2T -58U		CHECKED	<i>Gene W</i>	DATE	10-07-99'		DRAWING NO.	KJ-SMA6111A3-3GT50G-58U-50
1	BODY	NOTE 1	NOTE 2	1	SMA6111A3-1 -46/31		DRAWN	<i>Acia</i>	DATE	10-07-99'		FILE NO.	F:\DWG\SMA\6111A3\58U-50\3GT50G

SMARU4