

業務部

REVISIONS		
ISS	ZONE	DESCRIPTION\PER REQUEST\DATE

STAKE IN 4 PLACES
EQUALLY SPACED 90° APART
(打四點 間隔 90°)
(SEE REMARK 1,2)

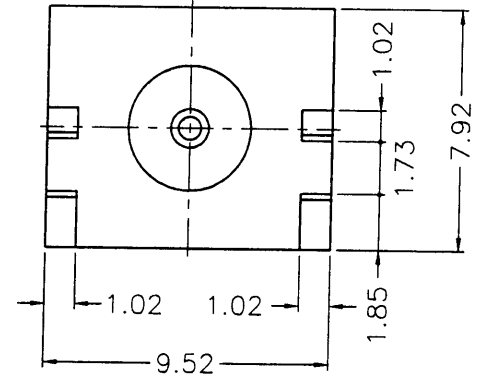
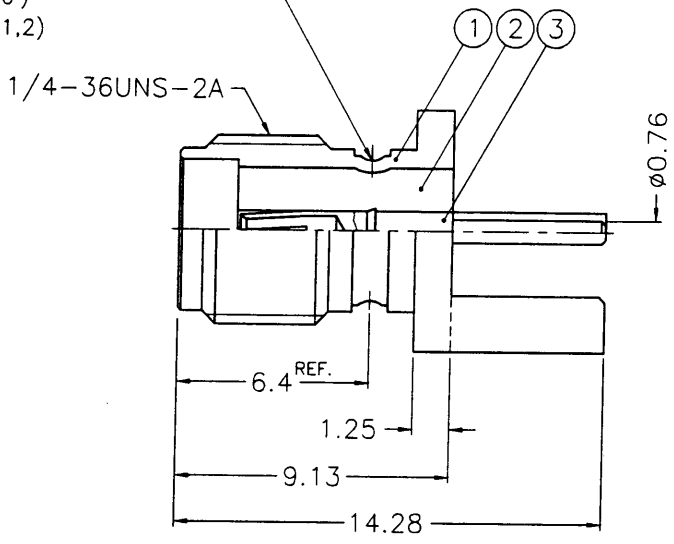

- NOTES: FINISH (PLATING THICKNESS IN MICRO-INCHES)
- BRASS PER QQ-B-626
 - GOLD PL. 3 MIN. THICK OVER NICKEL PL. 100 MIN. THICK OVER COPPER STRIKE
 - BERYLLIUM COPPER PER QQ-C-530
 - GOLD PL. 50 MIN. THICK OVER NICKEL PL. 100 MIN. THICK OVER COPPER STRIKE
 - TEFLON MIL-P-19468

- REMARK:1. NO.2 MUST WITHSTAND A 6 lbs. MIN. PUSHOUT FORCE FROM NO.1 AFTER STAKING OPERATION
2. REMARK1 IS MAINTAINED BY STAMPING THE FOUR POINTS SHOWN ON THE DRAWING WITHOUT PUNCTURING NO.1
- 打四點後零件 2 由零件 1 推出至少必須承受 6 磅推力)
 - 打四點後除需符合備註 1 要求外 且不可擊穿零件 1)



DIMENSIONS ARE IN MILLIMETERS					PART NO.		Amphenol - Kai Jack	
UNLESS OTHERWISE SPECIFIED TOLERANCES					APPROVED		TAINAN TAIWAN	
3	CONTACT PIN	NOTE 3	NOTE 4	1	SMA87091603-3	 DATE 08-14-00'	TITLE	
2	INSULATOR	NOTE 5	NATURAL	1	SMA87091603-2T-50-B		SMA END LAUNCH RECEPT. JACK	
1	BODY	NOTE 1	NOTE 2	1	SMA6251A1-011-1		DRAWING NO. KJ-SMA6251A1-011-3GT50G-50	
NO.	DESCRIPTION	MATERIAL	FINISH	Q'TY	DRAWING NO.	DRAWN	DATE	FILE NO. F:\DWG\SMA\6251A1\011\50\3GT50G