

1 2 3 4 5 6 7 8

REVISIONS		
ISS	ZONE	DESCRIPTION / APPROVED / DATE

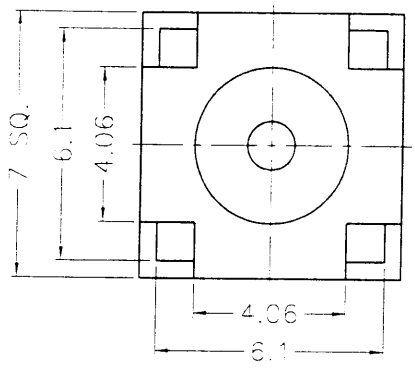

業務部

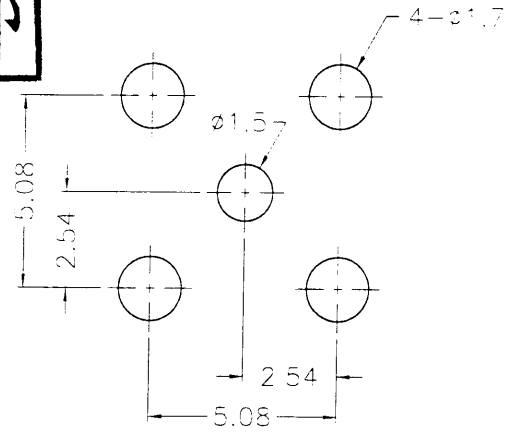

PCB MOUNTING HOLES

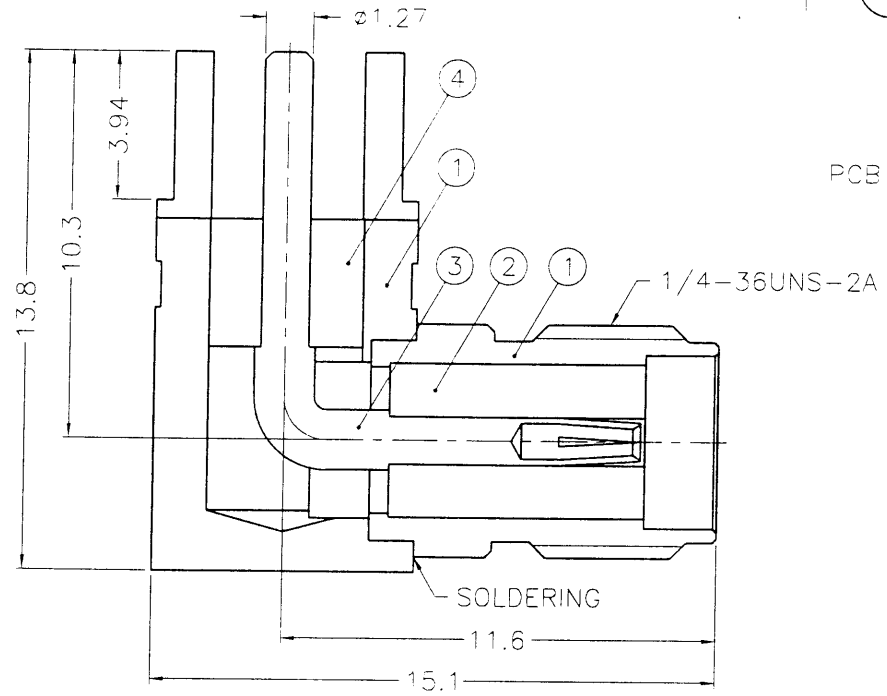

SOLDERING

- NOTES: FINISH (PLATING THICKNESS IN MICRO-INCHES)
- BRASS PER QQ-B-626
  - GOLD PL. 3 MIN. THICK OVER NICKEL PL. 100 MIN. THICK OVER COPPER STRIKE
  - BERYLLIUM COPPER PER QQ-C-530
  - COLD PL. 50 MIN. THICK OVER NICKEL PL. 100 MIN. THICK OVER COPPER STRIKE
  - TEFLON MIL-P-19468

出圖  
87.7.28  
R&D

NO.	DESCRIPTION	MATERIAL	FINISH	Q'TY	DRAWING NO.
4	INSULATOR	NOTE 5	NATURAL	1	SMA7790-5T-50
3	CONTACT FIN	NOTE 3	NOTE 4	1	SMA6252A2-4
2	INSULATOR	NOTE 5	NATURAL	1	SMA6252A2-3T-50-B
1	HOUSING WITH BODY	NOTE 1	NOTE 2	1	SMA6252A2-1S-B

DIMENSIONS ARE IN MILLIMETERS			
UNLESS OTHERWISE SPECIFIED TOLERANCES			
0.5-6	=	±0.2	
6-30	=	±0.4	
30-120	=	±0.6	
120-315	=	±1	
315-1000	=	±1.6	
1000-2000	=	±2.4	

PART NO.	
APPROVED	Mark C DATE 07-27-98'
CHECKED	Mark C DATE 07-27-98'
DRAWN	Shaly. w DATE 07-27-98'

KAI JACK INDUSTRIAL CO., LTD. TAINAN TAIWAN R.O.C.	
TITLE	SMA R/A P.C. MOUNT JACK
DRAWING NO.	KJ-SMA6252A2-3GT50G-50
FILE NO.	F:\DWG\SMA\6252A2\50\3GT50G

F  
E  
D  
C  
B  
A

1 2 3 4 5 6 7 8 8SMA RI>77