

REVISIONS			
ISS	ZONE	DESCRIPTION	PER REQUEST DATE

業務部

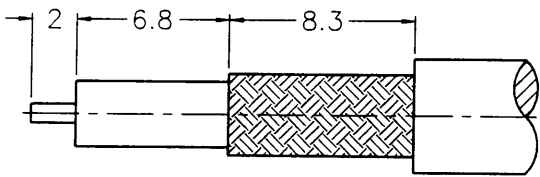

RECOMMENDED
CABLE STRIPPING DIM'S
(建議剝線尺寸)

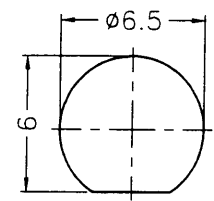

RECOMMENDED
MOUNTING HOLE
(建議架設孔)

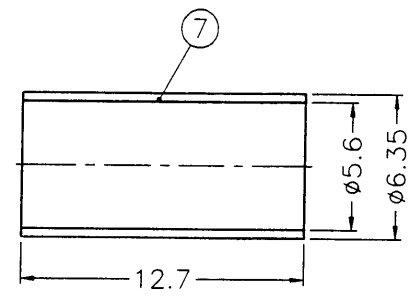
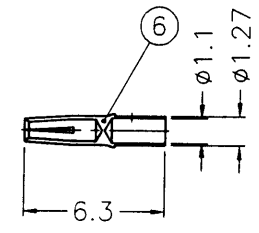
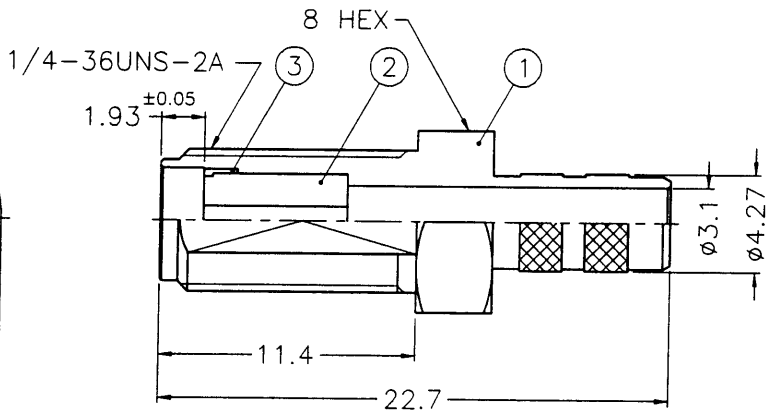
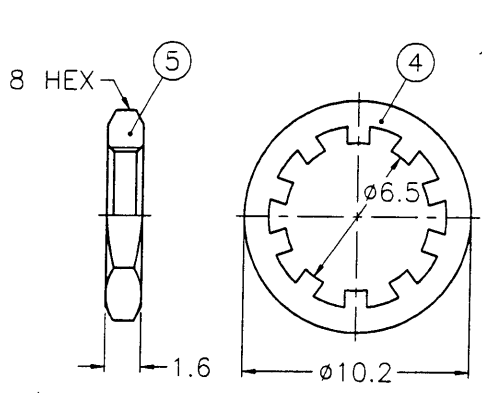

- NOTES: FINISH (PLATING THICKNESS IN MICRO-INCHES)
1. BRASS PER QQ-8-626
 2. BRASS PER QQ-8-613
 3. GOLD PL. 3 MIN. THICK OVER NICKEL PL. 100 MIN. THICK OVER COPPER STRIKE
 4. BERYLLIUM COPPER PER QQ-C-530
 5. GOLD PL. 50 MIN. THICK OVER NICKEL PL. 100 MIN. THICK OVER COPPER STRIKE
 6. TEFLON MIL-P-19468
 7. JIS H 3250, C 2700



1. CRIMPED FERRULE
HEX CRIMP SIZE .213"
2. CONTACT PIN TO SOLDER

NO.	DESCRIPTION	MATERIAL	FINISH	Q'TY	DRAWING NO.
7	FERRULE	NOTE 7	NOTE 3	1	FR-635/56X127
6	CONTACT PIN	NOTE 4	NOTE 5	1	SMA6511B3-3-127/11
5	HEX NUT	NOTE 1	NOTE 3	1	HN8-1/4-36X16
4	LOCK WASHER	NOTE 2	NOTE 3	1	LW-102/65X05
3	RING	NOTE 1	NOTE 3	1	SMA7071A4-4B
2	INSULATOR	NOTE 6	NATURAL	1	SMA6411A3-2T-50
1	BODY	NOTE 1	NOTE 3	1	SMA6411A3-1-427/31

DIMENSIONS ARE IN MILLIMETERS			
UNLESS OTHERWISE SPECIFIED TOLERANCES			
0.5-6	=	±0.2	
6-30	=	±0.4	
30-120	=	±0.6	
120-315	=	±1	
315-1000	=	±1.6	
1000-2000	=	±2.4	

PART NO.	
APPROVED	DATE
CHECKED	DATE
DRAWN	DATE

Amphenol - Kai Jack	
TAINAN TAIWAN	
TITLE SMA BULKHEAD CRIMP JACK (FOR RG-55/U, 142A/U, 223/U, 400/U)	
DRAWING NO. KJ-SMA6411A3-3GT50G-223U-50	
FILE NO. F:\DWG\SMA\6411A3\223U-50\3GT50G	

Approved: A. C. E. DATE: 08-09-00'
Checked: Jacky. DATE: 08-09-00'
Drawn: Joyce V. DATE: 08-09-00'