

REVISIONS		
ISS	ZONE	DESCRIPTION\PER REQUEST\DATE
B	B-1	NO.8 WAS CHANGED\RD-DM89091601I\09-16-00'

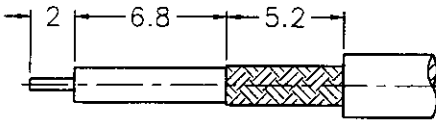

RECOMMENDED  
CABLE STRIPPING DIM'S  
(建議剝線尺寸)

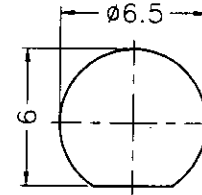

RECOMMENDED  
MOUNTING HOLE  
(建議架設孔)

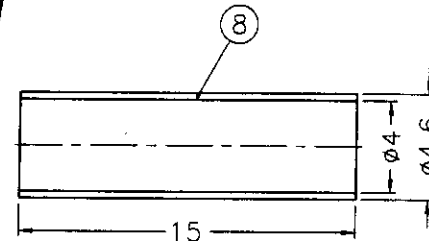
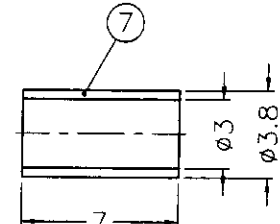
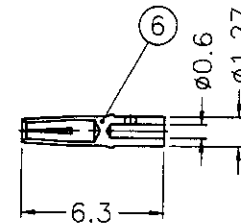
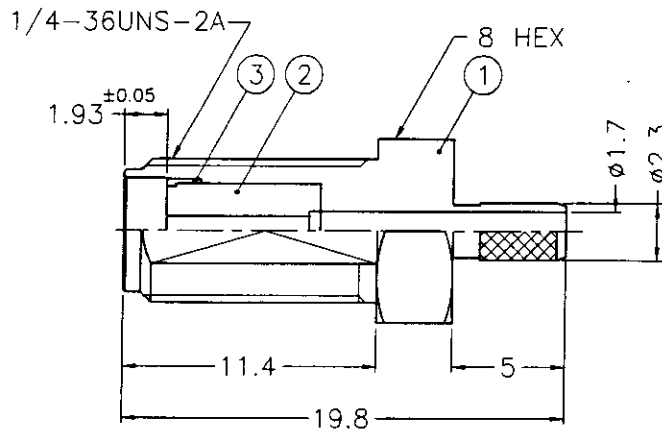
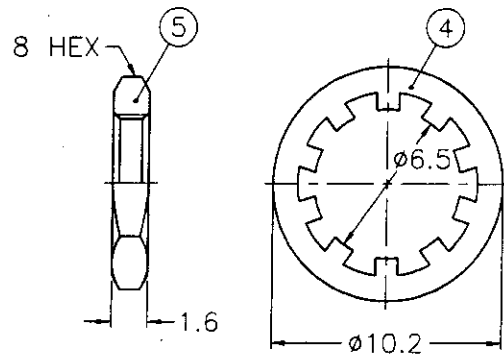

1. CRIMPED FERRULE  
HEX CRIMP SIZE .128"
2. CONTACT PIN TO SOLDER

NOTES: FINISH (PLATING THICKNESS IN MICRO-INCHES)

1. BRASS PER QQ-B-626
2. BRASS PER QQ-B-613
3. GOLD PL. 3 MIN. THICK OVER NICKEL PL. 100 MIN. THICK OVER COPPER STRIKE
4. BERYLLIUM COPPER PER QQ-C-530
5. GOLD PL. 50 MIN. THICK OVER NICKEL PL. 100 MIN. THICK OVER COPPER STRIKE
6. TEFLON MIL-P-19468



NO.	DESCRIPTION	MATERIAL	FINISH	Q'TY	DRAWING NO.
8	HEAT SHRINK TUBING		BLACK	1	HT-46/4X15
7	FERRULE	COPPER	NOTE 3	1	FR-38/3X7C
6	CONTACT PIN	NOTE 4	NOTE 5	1	SMA87051902-3
5	HEX NUT	NOTE 1	NOTE 3	1	HNB-1/4-36X16
4	LOCK WASHER	NOTE 2	NOTE 3	1	LW-102/65X05
3	RING	NOTE 1	NOTE 3	1	SMA7071A4-4B
2	INSULATOR	NOTE 6	NATURAL	1	SMA6411A4-2T-50
1	BODY	NOTE 1	NOTE 3	1	SMA6411A4-1-23/17

DIMENSIONS ARE IN MILLIMETERS			
UNLESS OTHERWISE SPECIFIED TOLERANCES			
0.5-6	=	±0.2	
6-30	=	±0.4	
30-120	=	±0.6	
120-315	=	±1	
315-1000	=	±1.6	
1000-2000	=	±2.4	

PART NO.	
APPROVED	DATE 09-19-00'
CHECKED	DATE 09-19-00'
DRAWN	DATE 09-19-00'

Amphenol - Kai Jack	
TAINAN TAIWAN	
TITLE	SMA BULKHEAD CRIMP JACK (FOR RG-174/U,188A/U,316/U)
DRAWING NO.	KJ-SMA6411A4-3GT50G-316U-50
FILE NO.	F:\DWG\SMA\6411A4\316U-50\3GT50G