

REVISIONS		
ISS	ZONE	DESCRIPTION\PER REQUEST\DATE

業務部

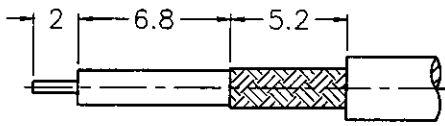

RECOMMENDED CABLE STRIPPING DIM'S (建議剝線尺寸)

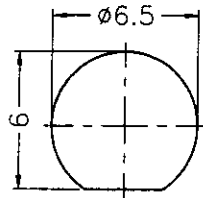

RECOMMENDED MOUNTING HOLE (建議架設孔)

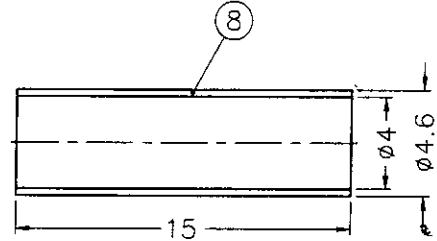
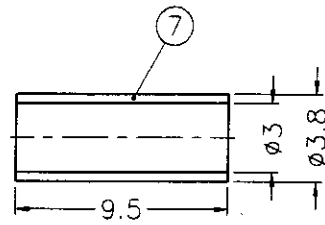
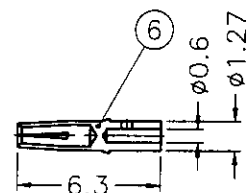
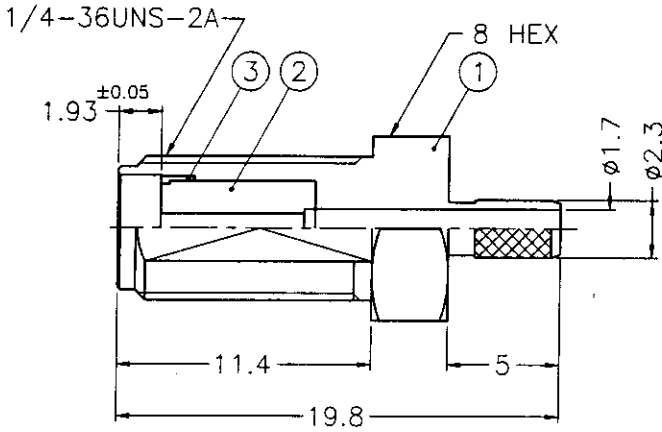
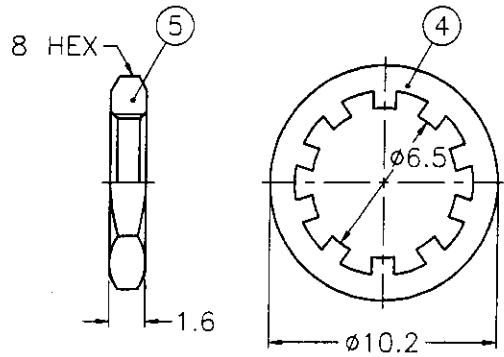

- NOTES: FINISH (PLATING THICKNESS IN MICRO-INCHES)
1. BRASS PER QQ-B-626
 2. BRASS PER QQ-B-613
 3. NICKEL PL. 100 MIN. THICK OVER COPPER STRIKE
 4. BERYLLIUM COPPER PER QQ-C-530
 5. GOLD PL. 50 MIN. THICK OVER NICKEL PL. 100 MIN. THICK OVER COPPER STRIKE
 6. TEFLON MIL-P-19468

1. CRIMPED FERRULE HEX CRIMP SIZE .128"
2. CONTACT PIN TO SOLDER
3. MAX. PANEL THICKNESS=3.2mm

出圖
2000.12.06
設計部

NO.	DESCRIPTION	MATERIAL	FINISH	Q'TY	DRAWING NO.
8	HEAT SHRINK TUBING		BLACK	1	HT-46/4X15
7	FERRULE	COPPER	NOTE 3	1	FR-38/3X95C
6	CONTACT PIN	NOTE 4	NOTE 5	1	SMA87051902-3
5	HEX NUT	NOTE 1	NOTE 3	1	HN8-1/4-36X16
4	LOCK WASHER	NOTE 2	NOTE 3	1	LW-102/65X05
3	RING	NOTE 1	NOTE 3	1	SMA7071A4-4B
2	INSULATOR	NOTE 6	NATURAL	1	SMA6411A4-2T-50
1	BODY	NOTE 1	NOTE 3	1	SMA6411A4-1-23/17

DIMENSIONS ARE IN MILLIMETERS			PART NO.	
UNLESS OTHERWISE SPECIFIED TOLERANCES			APPROVED	DATE
0.5-6	= ±0.2		<i>[Signature]</i>	12-05-00'
6-30	= ±0.4		CHECKED	DATE
30-120	= ±0.6		<i>[Signature]</i>	12-05-00'
120-315	= ±1		DRAWN	DATE
315-1000	= ±1.6		<i>[Signature]</i>	12-05-00'
1000-2000	= ±2.4			

Amphenol - Kai Jack	
TAINAN TAIWAN	
TITLE	SMA BULKHEAD CRIMP JACK (FOR RG-174/U,188A/U,316/U)
DRAWING NO.	KJ-SMA6411A4-NT50G-316U-50
FILE NO.	F:\DWG\SMA\6411A4\316U-50\NT50G

F
E
D
C
B
A

F
E
D
C
B
A