

業務部

1 2 3 4 5 6 7 8

REVISIONS		
NO.	ZONE	DESCRIPTION\PER REQUEST\DATE

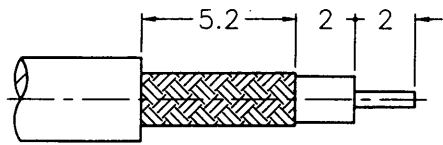

RECOMMENDED
CABLE STRIPPING DIM'S
(建議剝線尺寸)

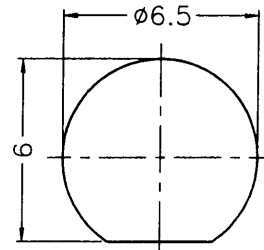

RECOMMENDED
MOUNTING HOLE
(建議架設孔)

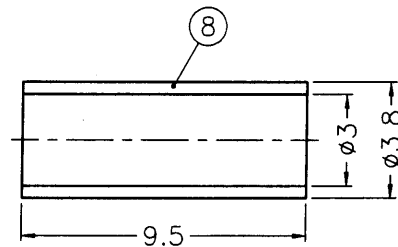
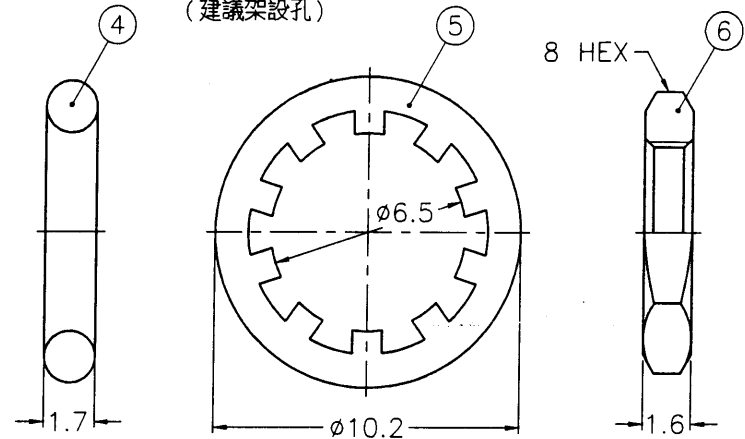
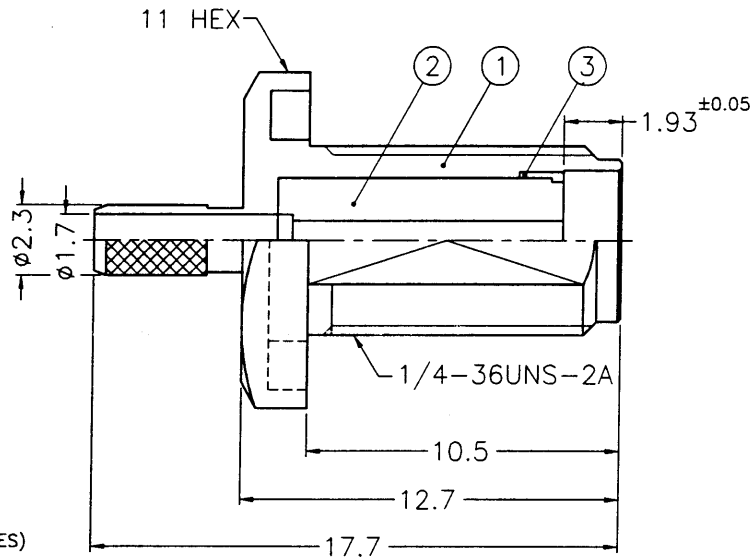
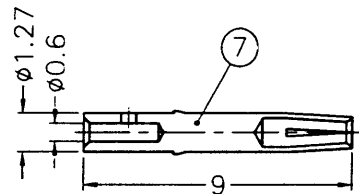

NOTES: FINISH (PLATING THICKNESS IN MICRO-INCHES)

- BRASS PER QQ-B-626
- BRASS PER QQ-B-613
- GOLD PL. 3 MIN. THICK OVER NICKEL PL. 100 MIN. THICK OVER COPPER STRIKE
- BERYLLIUM COPPER PER QQ-C-530
- GOLD PL. 50 MIN. THICK OVER NICKEL PL. 100 MIN. THICK OVER COPPER STRIKE
- TEFLON MIL-P-19468

出圖
2000.11.09
設計部

- CRIMPED FERRULE
HEX CRIMP SIZE .128"
- CONTACT PIN TO SOLDER
- MAX. PANEL THICKNESS=2.4mm

NO.	DESCRIPTION	MATERIAL	FINISH	Q'TY	DRAWING NO.
8	FERRULE	COPPER	NOTE 3	1	FR-38/3X95C
7	CONTACT PIN	NOTE 4	NOTE 5	1	SMA6411B2-7-127/06
6	HEX NUT	NOTE 1	NOTE 3	1	HN8-1/4-36X16
5	LOCK WASHER	NOTE 2	NOTE 3	1	LW-102/65X05
4	GASKET	SILICONE	RED	1	GS-99/65XD17
3	RING	NOTE 1	NOTE 3	1	SMA7071A4-4B
2	INSULATOR	NOTE 6	NATURAL	1	SMA6411B2-2T-50
1	BCDY	NOTE 1	NOTE 3	1	SMA6411B2-1-23/17

DIMENSIONS ARE IN MILLIMETERS			
UNLESS OTHERWISE SPECIFIED TOLERANCES			
0.5-6	=	±0.2	
6-30	=	±0.4	
30-120	=	±0.6	
120-315	=	±1	
315-1000	=	±1.6	
1000-2000	=	±2.4	

PART NO.	
APPROVED	DATE 11-07-00'
CHECKED	DATE 11-07-00'
DRAWN	DATE 11-07-00'

Amphenol - Kai Jack	
TAINAN TAIWAN	
TITLE	SMA BULKHEAD CRIMP JACK (FOR RG-174/U,188A/U,316/U)
DRAWING NO.	KJ-SMA6411B2-3GT50G-316U-50
FILE NO.	F:\DWG\SMA\6411B2\316U-50\3GT50G

F

E

D

C

B

A

1 2 3 4 5 6 7 8

RD 012-10977