

1 2 3 4 5 6 7 8

REVISIONS		
ISS	ZONE	DESCRIPTION\PER REQUEST\DATE
A1	A-3	NO.5 WAS CHANGED\N/A\12-26-01'

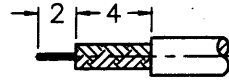

RECOMMENDED
CABLE STRIPPING DIM'S
(建議剝線尺寸)

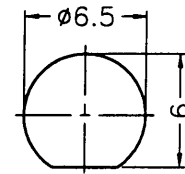

RECOMMENDED
MOUNTING HOLE
(建議架設孔)

SALES

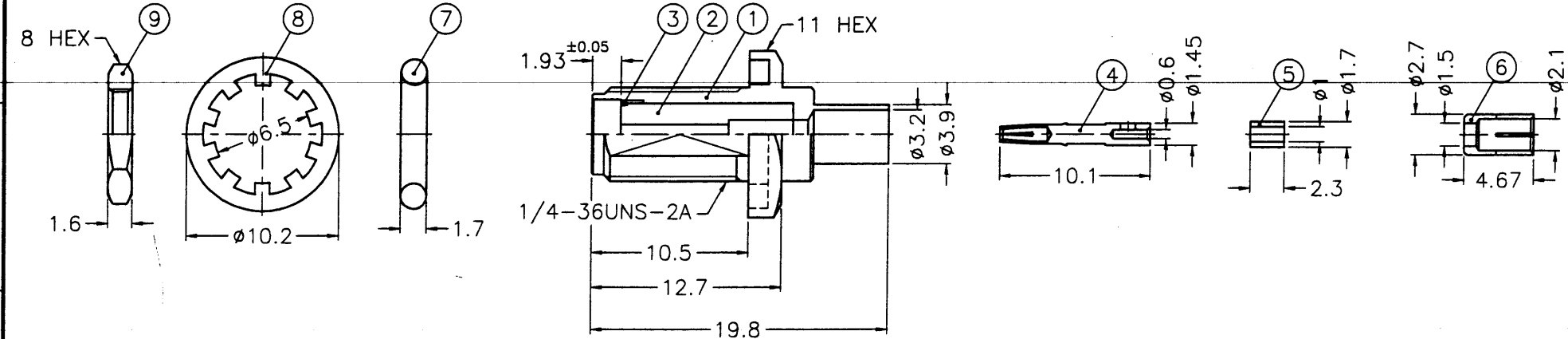

NOTES: FINISH (PLATING THICKNESS IN MICRO-INCHES)
 1. BRASS PER QQ-B-626
 2. BRASS PER QQ-B-613
 3. GOLD PL. 3 MIN. THICK OVER NICKEL PL. 100 MIN. THICK OVER COPPER STRIKE
 4. BERYLLIUM COPPER PER QQ-C-530
 5. GOLD PL. 50 MIN. THICK OVER NICKEL PL. 100 MIN. THICK OVER COPPER STRIKE
 6. TEFLON MIL-P-19468

ISSUED
2001.12.28
R&D

1. CRIMPED FERRULE
HEX CRIMP SIZE .128"
2. CONTACT PIN TO SOLDER

9	HEX NUT	NOTE 1	NOTE 3	1	HNB-1/4-36X16
8	LOCK WASHER	NOTE 2	NOTE 3	1	LW-102/65X05
7	GASKET	SILICONE	RED	1	GS-99/65XD17
6	FERRULE	NOTE 1	NOTE 3	1	SMA6411B4-6-27/21
5	INSULATOR	NOTE 6	NATURAL	1	7024-5
4	CONTACT PIN	NOTE 4	NOTE 5	1	SMA6111A3-3-145/06
3	RING	NOTE 1	NOTE 3	1	SMA7071A4-4B
2	INSULATOR	NOTE 6	NATURAL	1	SMA6411B4-2T-50
1	BODY	NOTE 1	NOTE 3	1	SMA6411B4-1-39/32

DIMENSIONS ARE IN MILLIMETERS		PART NO.	
UNLESS OTHERWISE SPECIFIED TOLERANCES		APPROVED	DATE
0.5-6 = ±0.2		<i>Mark C</i>	12-26-01'
6-30 = ±0.4		CHECKED	DATE
30-120 = ±0.6		<i>Mark C</i>	12-26-01'
120-315 = ±1		DRAWN	DATE
315-1000 = ±1.6		<i>Jeyo</i>	12-26-01'
1000-2000 = ±2.4			

Amphenol - Kai Jack	
TAINAN TAIWAN	
TITLE	SMA BULKHEAD CRIMP JACK (FOR RG-178B/U, 196A/U)
DRAWING NO.	KJ-SMA6411B4-3GT50G-196AU-50
ITEM NO.	116411AAD16GA5F

NO.	DESCRIPTION	MATERIAL	FINISH	Q'TY	DRAWING NO.	SCALE	2.5/1	ISSUE	A1	FILE NO.	F:\DWG\SMA\6411B4\196AU-50\3GT50G
-----	-------------	----------	--------	------	-------------	-------	-------	-------	----	----------	-----------------------------------

1 2 3 4 5 6 7 8