

1	REVISIONS
2	DESCRIPTION \ PER REQUEST \ DATE
3	

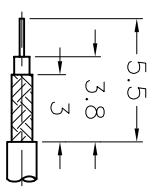

RECOMMENDED
CABLE STRIPPING DIM'S
(建議剝線尺寸)

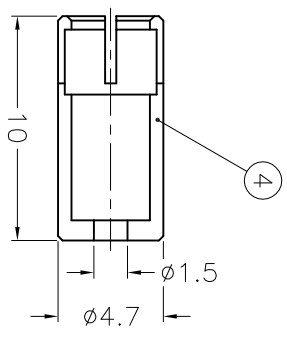
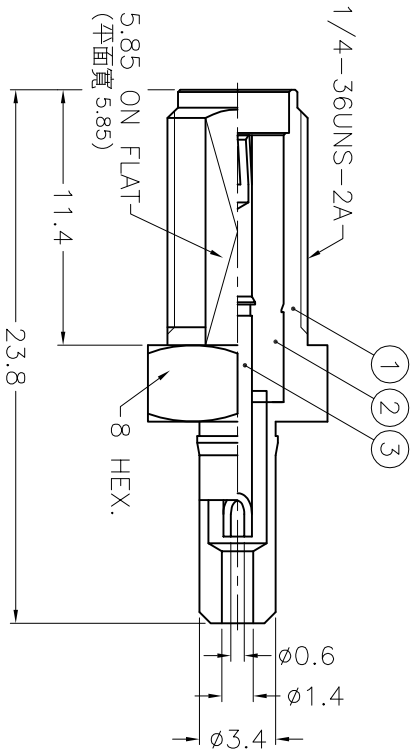
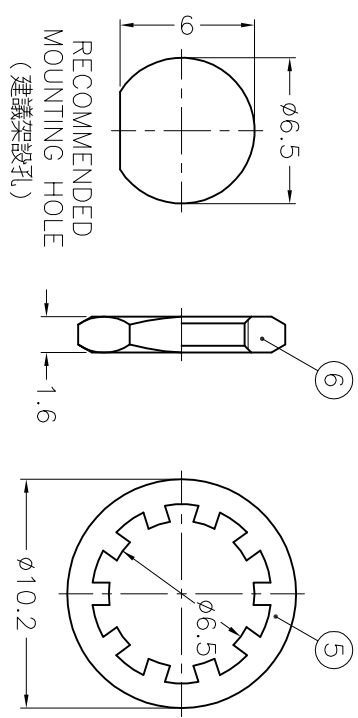

- NOTES: FINISH (PLATING THICKNESS IN MICRO-INCHES)
1. BRASS PER QQ-B-626
 2. BRASS PER QQ-B-613
 3. BERYLLIUM COPPER PER QQ-C-530
 4. GOLD P.L. 3 MIN. THICK OVER NICKEL P.L. 100 MIN. THICK OVER COPPER STRIKE
 5. GOLD P.L. 50 MIN. THICK OVER NICKEL P.L. 100 MIN. THICK OVER COPPER STRIKE
 6. TEFLON MIL-P-19468

1. CONTACT PIN TO SOLDER
2. MAX. PANEL THICKNESS=3.2mm

6	HEX NUT	NOTE 1	NOTE 4	1	HN8-1/4-36X16																
5	LOCK WASHER	NOTE 2	NOTE 4	1	LW-102/65X05																
4	FERRULE	NOTE 1	NOTE 4	1																	
3	CONTACT PIN	NOTE 3	NOTE 5	1	CP11AGY01A																
2	INSULATOR	NOTE 6	NATURAL	1	NS11ACJ02A																
1	BODY	NOTE 1	NOTE 4	1	BD11AJW01A																
NO.	DESCRIPTION	MATERIAL	FINISH	Q'TY	DRAWING NO.	SCALE	3/1	ISSUE	1	FILE NO.	F:\DWG\SMA\6411U1\002\50\3GT50G	ITEM NO.									
DIMENSIONS ARE IN MILLIMETERS												PART NO.									
UNLESS OTHERWISE SPECIFIED TOLERANCES												APPROVED									
0.5-6 = ±0.2												DATE									
6-30 = ±0.4												10-16-03'									
30-120 = ±0.6												CHECKED									
120-315 = ±1												DATE									
315-1000 = ±1.6												DRAWN									
1000-2000 = ±2.4												DATE									
												10-16-03'									
												TITLE									
												Danbury,CT,USA-Tainan,Taiwan-Shenzhen,China									
												Amphenol									
												SMA BULKHEAD JACK									
												(FOR 1.13 AND 1.32 CABLE)									
												DRAWING NO.									
												SMA6411U1-002-3GT50G-50									

A

B

C

D

E

F

A

B

C

D

E

F

1 2 3 4 5 6 7 8