

REVISIONS		
ISS	ZONE	DESCRIPTION\PER REQUEST\DATE

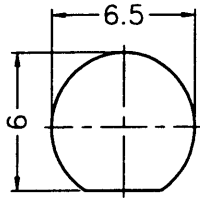

RECOMMENDED MOUNTING HOLE
(建議架設孔)

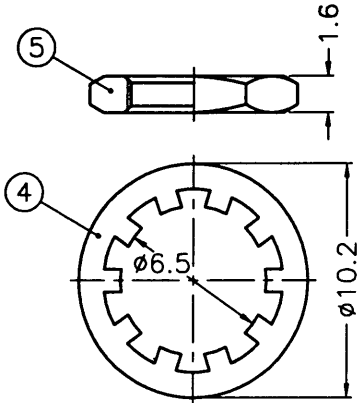

SALES

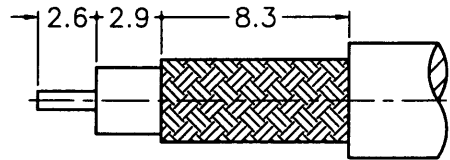

RECOMMENDED CABLE STRIPPING DIM'S
(建議剝線尺寸)

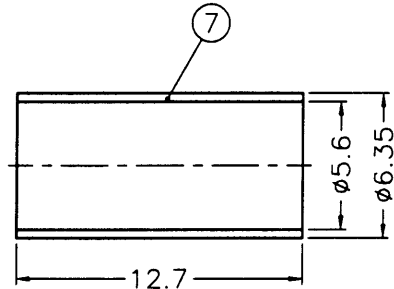
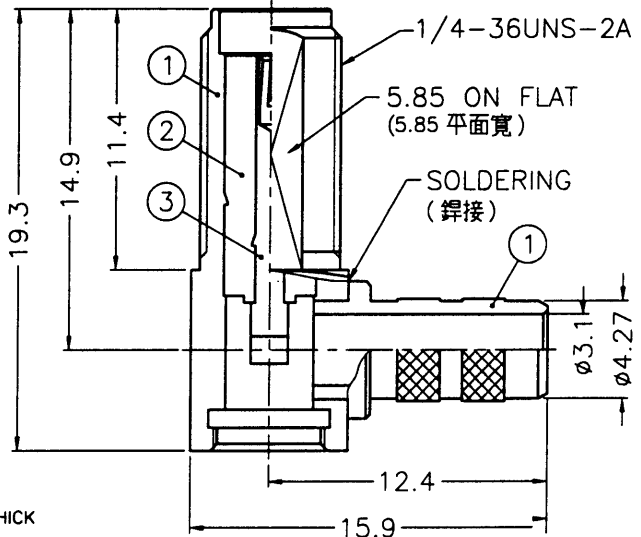

ISSUED
2002. 8. 29
R & D

NOTES: FINISH (PLATING THICKNESS IN MICRO-INCHES)

- BRASS PER QQ-B-626
- BRASS PER QQ-B-613
- GOLD PL. 3 MIN. THICK OVER NICKEL PL. 100 MIN. THICK OVER COPPER STRIKE
- BERYLLIUM COPPER PER QQ-C-530
- GOLD PL. 50 MIN. THICK OVER NICKEL PL. 100 MIN. THICK OVER COPPER STRIKE
- TEFLON MIL-P-19468
- JIS H 3250, C 2600

- CRIMPED FERRULE
HEX. CRIMP SIZE .213"
- CONTACT PIN TO SOLDER
- MAX. PANEL THICKNESS=3.2mm

NO.	DESCRIPTION	MATERIAL	FINISH	Q'TY	DRAWING NO.
7	FERRULE	NOTE 7	NOTE 3	1	FR-635/56X127
6	COVER	NOTE 1	NOTE 3	1	DMT-2004-004N-8
5	HEX NUT	NOTE 1	NOTE 3	1	HNB-1/4-36X16
4	LOCK WASHER	NOTE 2	NOTE 3	1	LW-102/65X05
3	CONTACT PIN	NOTE 4	NOTE 5	1	SMA6412B1-3
2	INSULATOR	NOTE 6	NATURAL	1	SMA6412B1-2
1	BODY WITH BARREL	NOTE 1	NOTE 3	1	MB11ACA01A

DIMENSIONS ARE IN MILLIMETERS				PART NO.	
UNLESS OTHERWISE SPECIFIED TOLERANCES				APPROVED	DATE
0.5-6	= ±0.2			<i>gawkey</i>	08-27-02'
6-30	= ±0.4			CHECKED	DATE
30-120	= ±0.6			<i>Ken</i>	08-27-02'
120-315	= ±1			DRAWN	DATE
315-1000	= ±1.6			<i>Ken</i>	08-27-02'
1000-2000	= ±2.4			FILE NO.	F:\DWG\SMA\6412A2\223U-50\3GT50G

Amphenol - Kai Jack	
TAINAN TAIWAN	
TITLE	SMA R/A BULKHEAD JACK (FOR RG-55/U,142A/U,223/U,400/U)
DRAWING NO.	KJ-SMA6412A2-3GT50G-223U-50
ITEM NO.	116412AAC26GA5F