

REVISIONS			
ISS	ZONE	DESCRIPTION\PER REQUEST\DATE	

業務部

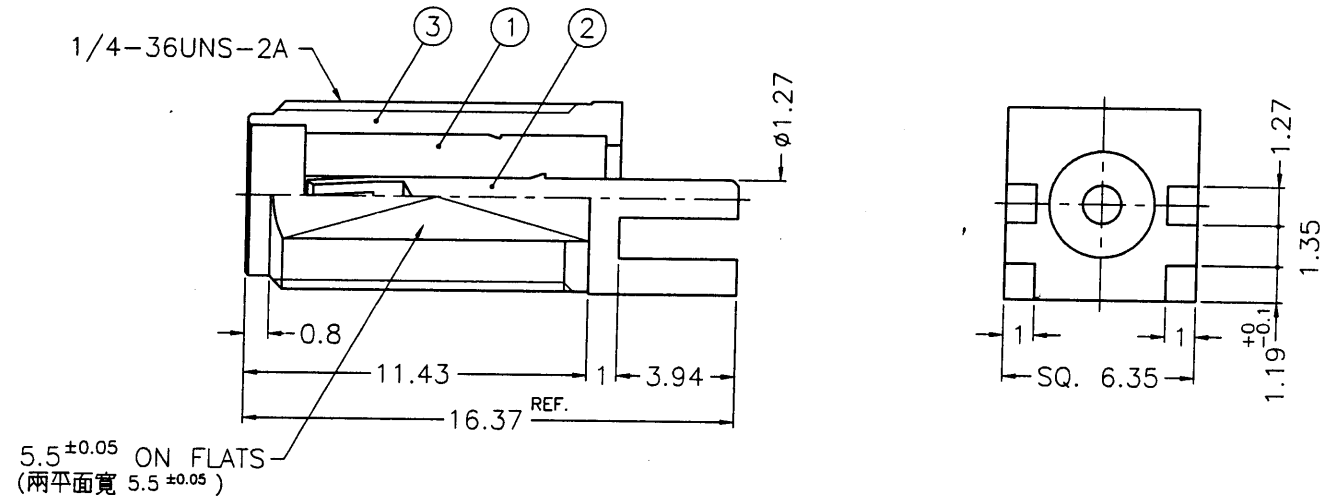

- NOTES: FINISH (PLATING THICKNESS IN MICRO-INCHES)
- BRASS PER QQ-B-626
  - GOLD PL. 10 MIN. THICK OVER NICKEL PL. 100 MIN. THICK OVER COPPER STRIKE
  - BERYLLIUM COPPER PER QQ-C-530
  - GOLD PL. 50 MIN. THICK OVER NICKEL PL. 100 MIN. THICK OVER COPPER STRIKE
  - TEFLON MIL-P-19468

出圖  
89.5.24  
設計部

DIMENSIONS ARE IN MILLIMETERS				PART NO.		<b>Amphenol - Kai Jack</b> TAINAN TAIWAN	
UNLESS OTHERWISE SPECIFIED TOLERANCES				APPROVED <i>Andy C</i> DATE 05-23-00'			
0.5-6 = ±0.2				CHECKED <i>Andy C</i> DATE 05-23-00'		TITLE SMA END LAUNCH JACK	
6-30 = ±0.4				DRAWN <i>Irene L</i> DATE 05-23-00'		DRAWING NO. KJ-SMA645100-003-10GT50G-G	
30-120 = ±0.6				FILE NO. F:\DWG\SMA\645100\003\10GT50G-G			
120-315 = ±1							
315-1000 = ±1.6							
1000-2000 = ±2.4							

NO.	DESCRIPTION	MATERIAL	FINISH	Q'TY	DRAWING NO.
3	BODY			1	SMA645100-003-3
2	CONTACT PIN			1	SMA645100-001-2BE
1	INSULATOR		NATURAL	1	SMA645100-001-1

81514