

REVISIONS		
ISS	ZONE	DESCRIPTION\PER REQUEST\DATE

業務部

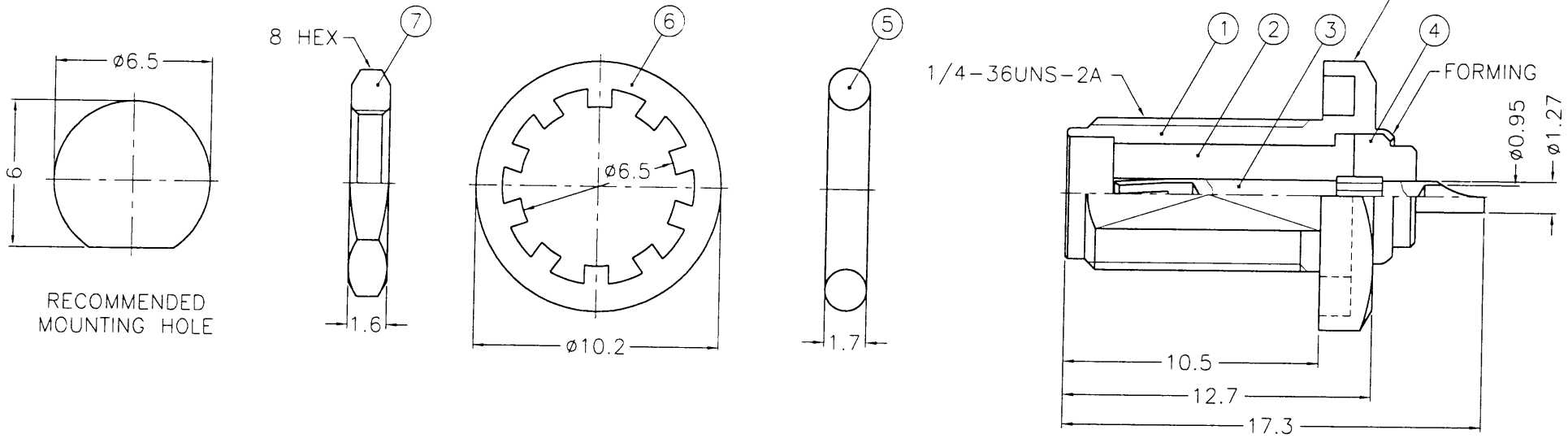

NOTES: FINISH (PLATING THICKNESS IN MICRO-INCHES)
 1. BRASS PER QQ-B-626
 2. BRASS PER QQ-B-613
 3. GOLD PL. 3 MIN. THICK OVER NICKEL PL. 100 MIN. THICK OVER COPPER STRIKE
 4. BERYLLIUM COPPER PER QQ-C-530
 5. GOLD PL. 50 MIN. THICK OVER NICKEL PL. 100 MIN. THICK OVER COPPER STRIKE
 6. TEFLON MIL-P-19468

出圖
88.4.28

NO.	DESCRIPTION	MATERIAL	FINISH	Q'TY	DRAWING NO.
7	HEX NUT	NOTE 1	NOTE 3	1	HN8-1/4-36X16
6	LOCK WASHER	NOTE 2	NOTE 3	1	LW-102/65X05
5	GASKET	SILICONE	RED	1	GS-99/65XD17
4	INSULATOR	NOTE 6	NATURAL	1	SMA7301-4T-50
3	CONTACT PIN	NOTE 4	NOTE 5	1	SMA7301-3
2	INSULATOR	NOTE 6	NATURAL	1	SMA7301-2T-50
1	BODY	NOTE 1	NOTE 3	1	SMA7430-1-B

DIMENSIONS ARE IN MILLIMETERS			PART NO	
UNLESS OTHERWISE SPECIFIED TOLERANCES			APPROVED	DATE
0.5-6	= ±0.2		<i>Mark C</i>	04-26-99'
6-30	= ±0.4		CHECKED	DATE
30-120	= ±0.6		<i>Mark C</i>	04-26-99'
120-315	= ±1		DRAWN	DATE
315-1000	= ±1.6		<i>Ada</i>	04-26-99'
1000-2000	= ±2.4			

KAI JACK INDUSTRIAL CO., LTD.
TAINAN TAIWAN R.O.C.

TITLE: SMA BULKHEAD RECEPT. JACK

DRAWING NO. KJ-SMA6451A1-3GT50G-50

FILE NO. F:\DWG\SMA\6451A1\50\3GT50G

A

A