

業務部

REVISIONS		
ISS	ZONE	DESCRIPTION\APPROVED\DATE

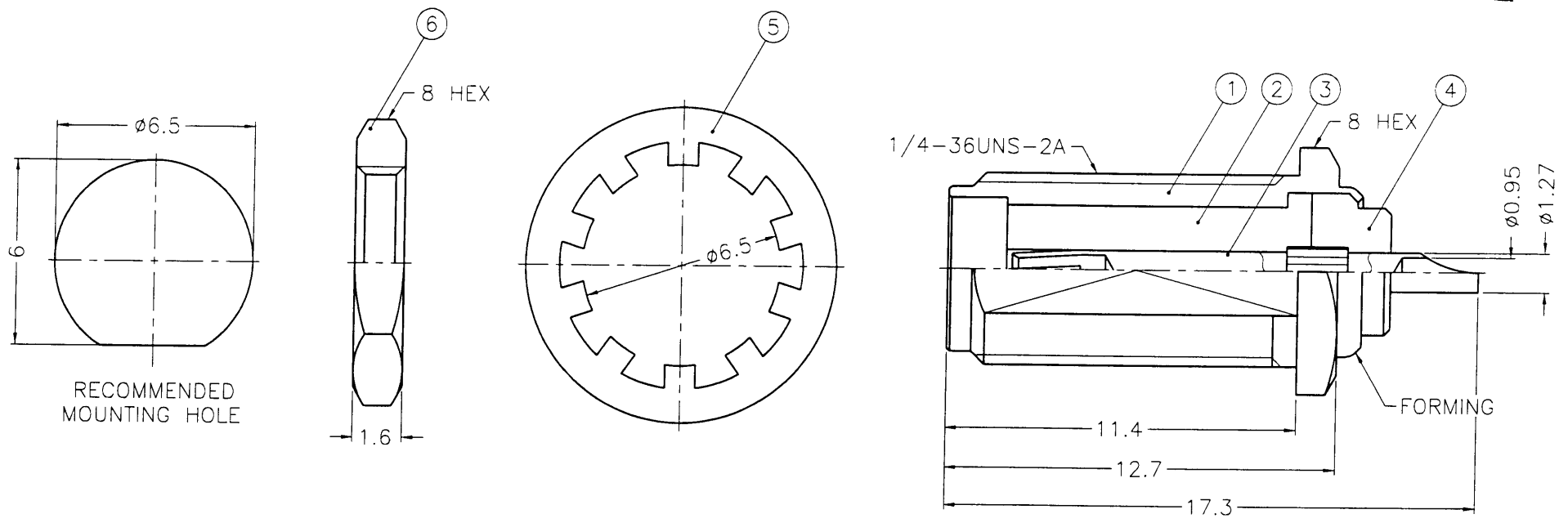

NOTES: FINISH (PLATING THICKNESS IN MICRO-INCHES)
 1. BRASS PER QQ-B-626
 2. BRASS PER QQ-B-613
 3. GOLD PL. 3 MIN. THICK OVER NICKEL PL. 100 MIN. THICK OVER COPPER STRIKE
 4. BERYLLIUM COPPER PER QQ-C-530
 5. GOLD PL. 50 MIN. THICK OVER NICKEL PL. 100 MIN. THICK OVER COPPER STRIKE
 6. TEFLON MIL-P-19468

出圖 87.9.22 R&D
 出圖 87.9.22 R&L

NO.	DESCRIPTION	MATERIAL	FINISH	Q'TY	DRAWING NO.
6	HEX NUT	NOTE 1	NOTE 3	1	HN8-1/4-36X16
5	LOCK WASHER	NOTE 2	NOTE 3	1	LW-102/65X05
4	INSULATOR	NOTE 6	NATURAL	1	SMA7301-4T-50
3	CONTACT PIN	NOTE 4	NOTE 5	1	SMA7301-3
2	INSULATOR	NOTE 6	NATURAL	1	SMA7301-2T-50
1	BODY	NOTE 1	NOTE 3	1	SMA7301-1-B

DIMENSIONS ARE IN MILLIMETERS			PART NO.	
UNLESS OTHERWISE SPECIFIED TOLERANCES			APPROVED <i>Mark C</i> DATE 09-21-98'	
0.5-6	= ±0.2		CHECKED <i>Mark C</i> DATE 09-21-98'	
6-30	= ±0.4		DRAWN <i>Betty S</i> DATE 09-21-98'	
30-120	= ±0.6		SCALE 5/1 ISSUE A	
120-315	= ±1			
315-1000	= ±1.6			
1000-2000	= ±2.4			

KAI JACK INDUSTRIAL CO., LTD.
 TAINAN TAIWAN R.O.C.

TITLE: SMA BULKHEAD RECEPT. JACK

DRAWING NO.: KJ-SMA6451B1-3GT50G-50

FILE NO.: F:\DWG\SMA\6451B1\50\3GT50G

F
E
D
C
B
A