

REVISIONS		
ISS	ZONE	DESCRIPTION\PER REQUEST\DATE
B	A-1	NO.3 WAS CHANGED\RD-DM89103101Y\10-31-00'

業務部

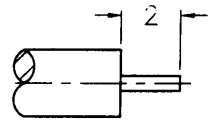

RECOMMENDED  
CABLE STRIPPING DIM'S  
(建議剝線尺寸)

F  
E  
D  
C  
B  
A

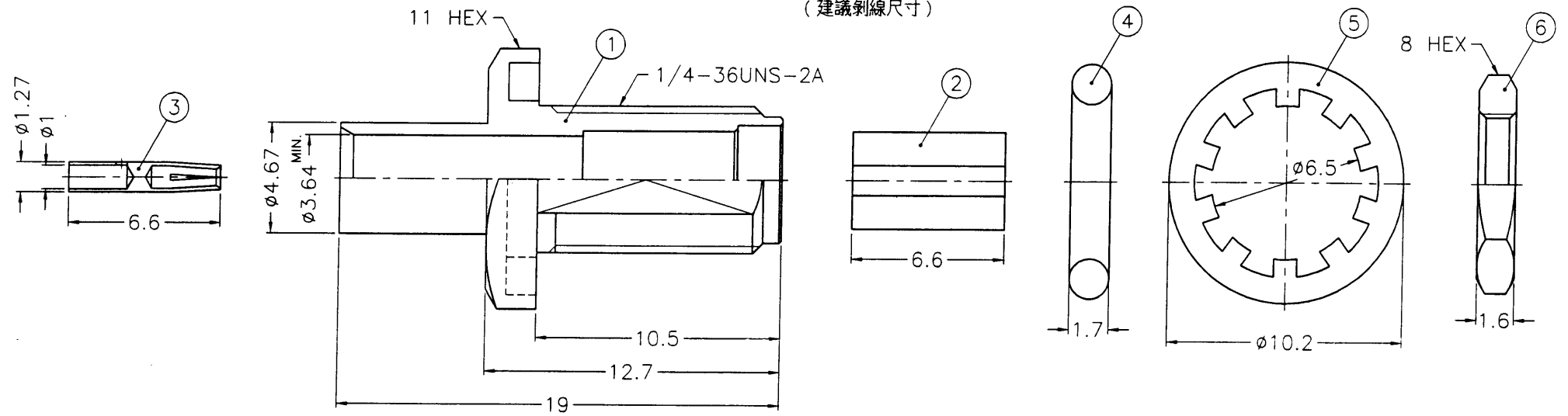

- NOTES: FINISH (PLATING THICKNESS IN MICRO-INCHES)
- BRASS PER QQ-B-626
  - BRASS PER QQ-B-613
  - GOLD PL. 3 MIN. THICK OVER NICKEL PL. 100 MIN. THICK OVER COPPER STRIKE
  - GOLD PL. 50 MIN. THICK OVER NICKEL PL. 100 MIN. THICK OVER COPPER STRIKE
  - BERYLLIUM COPPER PER QQ-C-530
  - TEFLON MIL-P-19468

出圖  
2000. 11. 04  
設計部

- CONTACT PIN TO SOLDER
- MAX. PANEL THICKNESS=2.4mm

NO.	DESCRIPTION	MATERIAL	FINISH	Q'TY	DRAWING NO.	SCALE	4/1	ISSUE	B	DIMENSIONS ARE IN MILLIMETERS UNLESS OTHERWISE SPECIFIED TOLERANCES	PART NO.	TITLE	
6	HEX NUT			1	HN8-1/4-36X16					0.5-6 = ±0.2		Amphenol - Kai Jack	
5	LOCK WASHER			1	LW-102/65X05					6-30 = ±0.4		TAINAN TAIWAN	
4	GASKET	SILICONE	RED	1	GS-99/65XD17					30-120 = ±0.6	APPROVED	TITLE	
3	CONTACT PIN			1	SMA7081-3-127/1-B					120-315 = ±1	DATE	SMA DIRECT SOLDER BULKHEAD JACK	
2	INSULATOR		NATURAL	1	SMA7081-2T-50					315-1000 = ±1.6	CHECKED	DRAWING NO.	
1	BODY			1	SMA7481-1-467/364-C					1000-2000 = ±2.4	DATE	KJ-SMA6481A1-3GT50G-.141-50	
											DRAWN	DATE	FILE NO.
												10-27-00'	F:\DWG\SMA\6481A1\141-50\3GT50G

*gacky*  
*Jaya*