

1 2 3 4 5 6 7 8

REVISIONS		
ISS	ZONE	DESCRIPTION\PER REQUEST\DATE

業務部

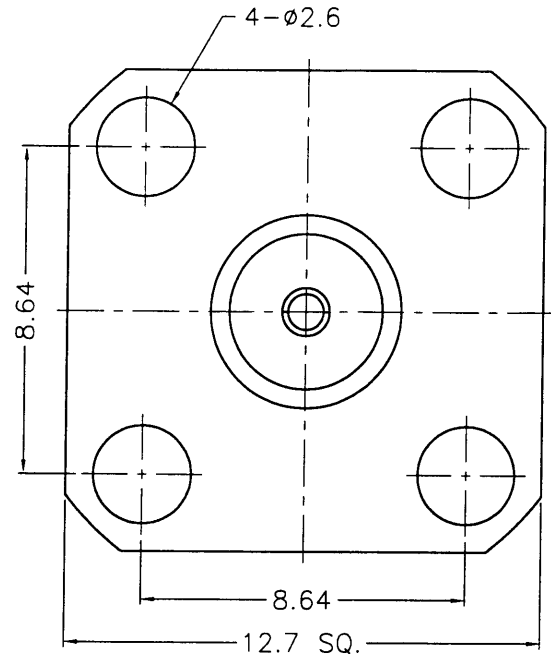
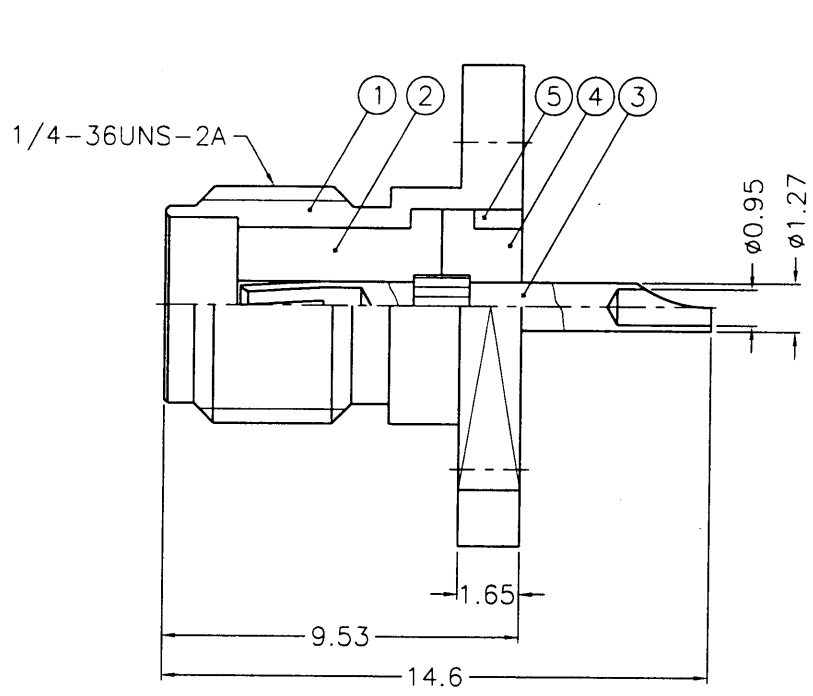

NOTES: FINISH (PLATING THICKNESS IN MICRO-INCHES)

1. BRASS PER QQ-B-626
2. GOLD PL. 3 MIN. THICK OVER NICKEL PL. 100 MIN. THICK OVER COPPER STRIKE
3. BERYLLIUM COPPER PER QQ-C-530
4. GOLD PL. 50 MIN. THICK OVER NICKEL PL. 100 MIN. THICK OVER COPPER STRIKE
5. TEFLON MIL-P-19468

88.5.05

DIMENSIONS ARE IN MILLIMETERS			
UNLESS OTHERWISE SPECIFIED TOLERANCES			
0.5-6	=	±0.2	
6-30	=	±0.4	
30-120	=	±0.6	
120-315	=	±1	
315-1000	=	±1.6	
1000-2000	=	±2.4	

PART NO.	
APPROVED	DATE
CHECKED	DATE
DRAWN	DATE

KAI JACK INDUSTRIAL CO., LTD. TAINAN TAIWAN R.O.C.	
TITLE	
SMA PANEL RECEPT. JACK	
DRAWING NO.	
KJ-SMA6551A1-3GT50G-50	
FILE NO. F:\DWG\SMA\6551A1\50\3GT50G	

NO.	DESCRIPTION	MATERIAL	FINISH	Q'TY	DRAWING NO.
5	RING		NOTE 1	1	SMA7530-5-B
4	INSULATOR		NOTE 5	1	SMA7530-4T-50
3	CONTACT PIN		NOTE 3	1	SMA7530-3
2	INSULATOR		NOTE 5	1	SMA7530-2T-50-B
1	BODY		NOTE 1	1	SMA7530-1-B

F
E
D
C
B
A

F
E
D
C
B
A

SMA P1535