

1 2 3 4 5 6 7 8

REVISIONS		
ISS	ZONE	DESCRIPTION \ APPROVED \ DATE

業務部

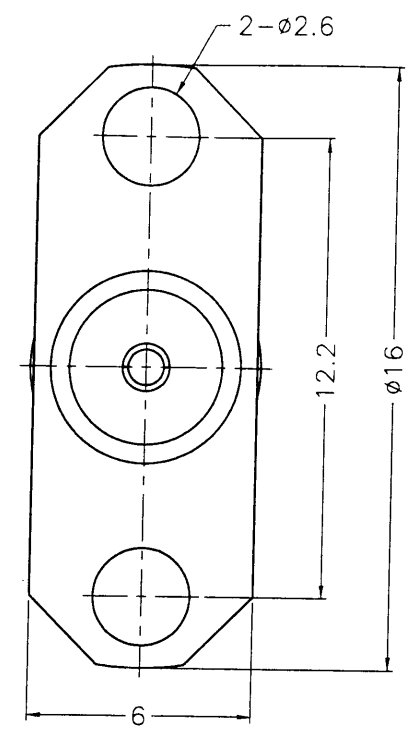
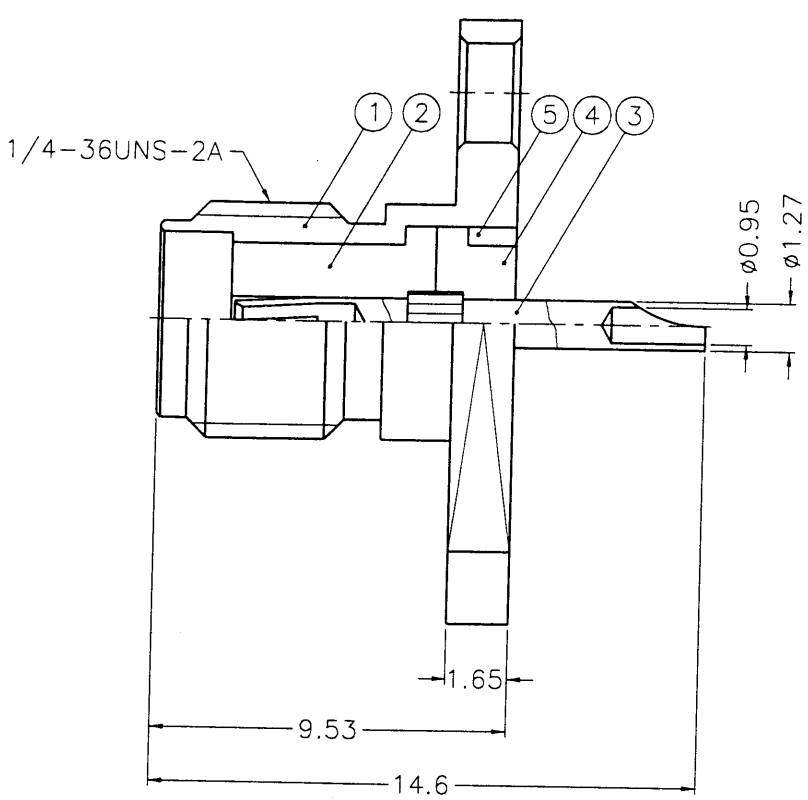

NOTES: FINISH (PLATING THICKNESS IN MICRO-INCHES)  
 1. BRASS PER QQ-B-626  
 2. GOLD PL. 3 MIN. THICK OVER NICKEL PL. 100 MIN. THICK OVER COPPER STRIKE  
 3. BERYLLIUM COPPER PER QQ-C-530  
 4. GOLD PL. 50 MIN. THICK OVER NICKEL PL. 100 MIN. THICK OVER COPPER STRIKE  
 5. TEFLON MIL-P-19468

出圖  
87.9.07  
R&D

DIMENSIONS ARE IN MILLIMETERS					PART NO.				
NO.	DESCRIPTION	MATERIAL	FINISH	Q'TY	DRAWING NO.	SCALE		ISSUE	A
5	RING		NOTE 1	NOTE 2	1	SMA7530-5-B	UNLESS OTHERWISE SPECIFIED TOLERANCES		APPROVED
4	INSULATOR		NOTE 5	NATURAL	1	SMA7530-4T-50	0.5-6 = ±0.2		DATE
3	CONTACT PIN		NOTE 3	NOTE 4	1	SMA7530-3	6-30 = ±0.4		09-03-98'
2	INSULATOR		NOTE 5	NATURAL	1	SMA7530-2T-50-B	30-120 = ±0.6		DATE
1	BODY		NOTE 1	NOTE 2	1	SMA7535-1-B	120-315 = ±1		09-03-98'
							315-1000 = ±1.6		DATE
							1000-2000 = ±2.4		09-03-98'
									FILE NO. F:\DWG\SMA\6551B1\50\3GT50G

APPROVED *Stacy E* DATE 09-03-98'  
 CHECKED *Conce. W* DATE 09-03-98'  
 DRAWN *Betty S* DATE 09-03-98'

85M/R 1314