

1 2 3 4 5 6 7 8

REVISIONS		
ISS	ZONE	DESCRIPTION\PER REQUEST\DATE

業務部

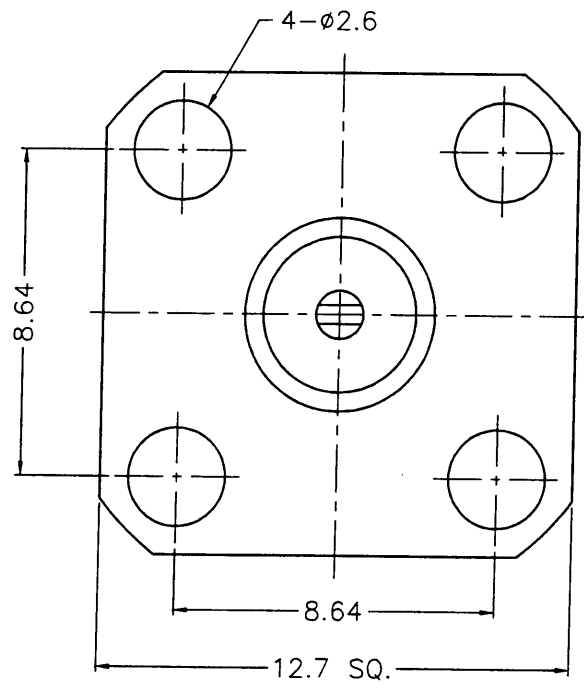
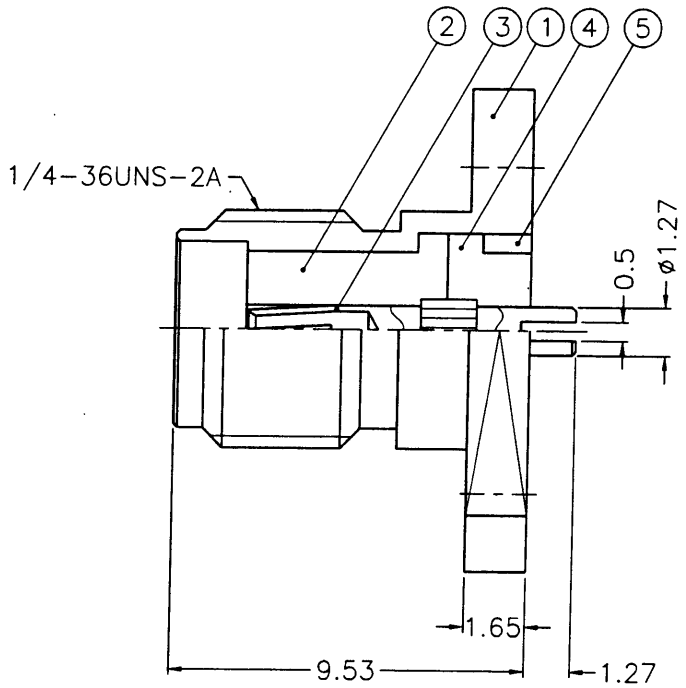

NOTES: FINISH (PLATING THICKNESS IN MICRO-INCHES)
 1. BRASS PER QQ-B-626
 2. GOLD PL. 3 MIN. THICK OVER NICKEL PL. 100 MIN. THICK OVER COPPER STRIKE
 3. BERYLLIUM COPPER PER QQ-C-530
 4. GOLD PL. 50 MIN. THICK OVER NICKEL PL. 100 MIN. THICK OVER COPPER STRIKE
 5. TEFLON MIL-P-19468

2000. 10. 20

DIMENSIONS ARE IN MILLIMETERS			
UNLESS OTHERWISE SPECIFIED TOLERANCES			
0.5-6	=	±0.2	
6-30	=	±0.4	
30-120	=	±0.6	
120-315	=	±1	
315-1000	=	±1.6	
1000-2000	=	±2.4	

PART NO.	
APPROVED	DATE 10-17-00'
CHECKED	DATE 10-17-00'
DRAWN	DATE 10-17-00'

Amphenol - Kai Jack	
TAINAN TAIWAN	
TITLE SMA PANEL RECEPT. JACK	
DRAWING NO. KJ-SMA6551C1-3GT50G-0.5-50	
FILE NO. F:\DWG\SMA\6551C1\05-50\3GT50G	

NO.	DESCRIPTION	MATERIAL	FINISH	Q'TY	DRAWING NO.
5	RING		NOTE 1	1	SMA7530-5-B
4	INSULATOR		NOTE 5	1	SMA7530-4T-50
3	CONTACT PIN		NOTE 3	1	SMA7540-3-0.5
2	INSULATOR		NOTE 5	1	SMA7530-2T-50-B
1	BODY		NOTE 1	1	SMA7530-1-B

1 2 3 4 5 6 7 8