

1 2 3 4 5 6 7 8

REVISIONS		
ISS	ZONE	DESCRIPTION\APPROVED\DATE
-	A-7	SMA6551C1 WAS SMA7540\TONY. T\01-18-93'
B	A-1	NO.2 WAS NO.5 CHANGED\TONY. T\03-25-97'
C	A-1	NO.1 WAS CHANGED\TONY. T\05-18-98'

業務部

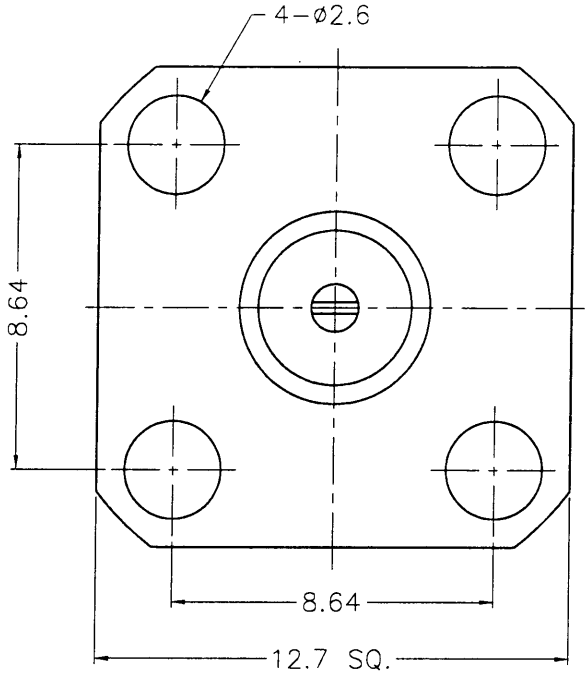
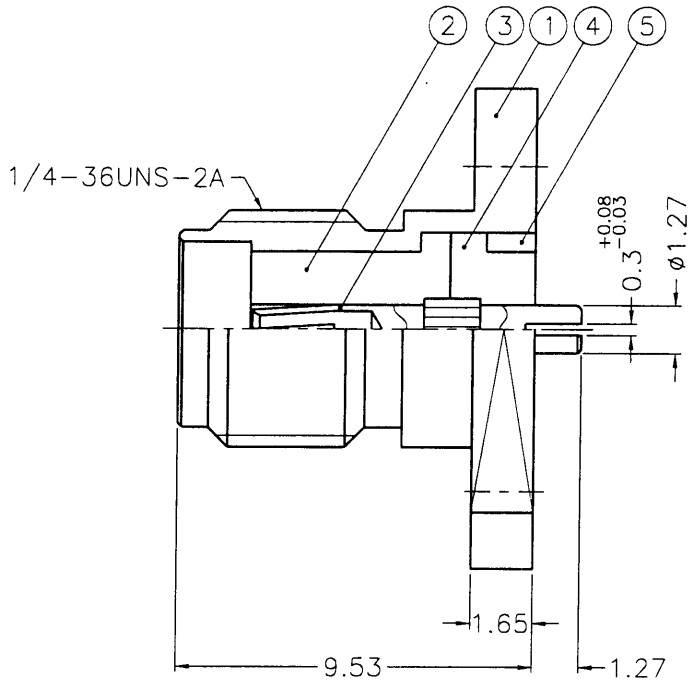

- NOTES: 1. PER KAI JACK SPEC. EP-SS-9700  
 2. BRASS PER QQ-B-626  
 STAINLESS STEEL PER QQ-S-764, TYPE 303  
 3. BERYLLIUM COPPER PER QQ-C-530  
 4. TEFLON MIL-P-19468

出圖  
87.7.02  
R&D

DIMENSIONS ARE IN MILLIMETERS				PART NO.								
5	RING	NOTE 2	NOTE 1	1	SMA7530-5-B		TITLE					
4	INSULATOR	NOTE 4	NATURAL	1	SMA7530-4T-50	SMA PANEL RECEPT. JACK						
3	CONTACT PIN	NOTE 3	NOTE 1	1	SMA7540-3-0.35							
2	INSULATOR	NOTE 4	NATURAL	1	SMA7530-2T-50	DRAWING NO.						
1	BODY	NOTE 2	NOTE 1	1	SMA7530-1-B	KJ-SMA6551C1-0.3-50						
NO.	DESCRIPTION	MATERIAL	FINISH	Q'TY	DRAWING NO.	SCALE	5/1	ISSUE	C	APPROVED	DATE	FILE NO.
										<i>Golden. w</i> <i>Golden. w</i> <i>Shaly. w</i>	06-30-98'	F:\DWG\SMA\6551C1\0.3-50

F  
E  
D  
C  
B  
A

F  
E  
D  
C  
B  
A

1 2 3 4 5 6 7 8 SMA-R1258