

1 2 3 4 5 6 7 8

REVISIONS		
ISS	ZONE	DESCRIPTION \ APPROVED \ DATE

業務部

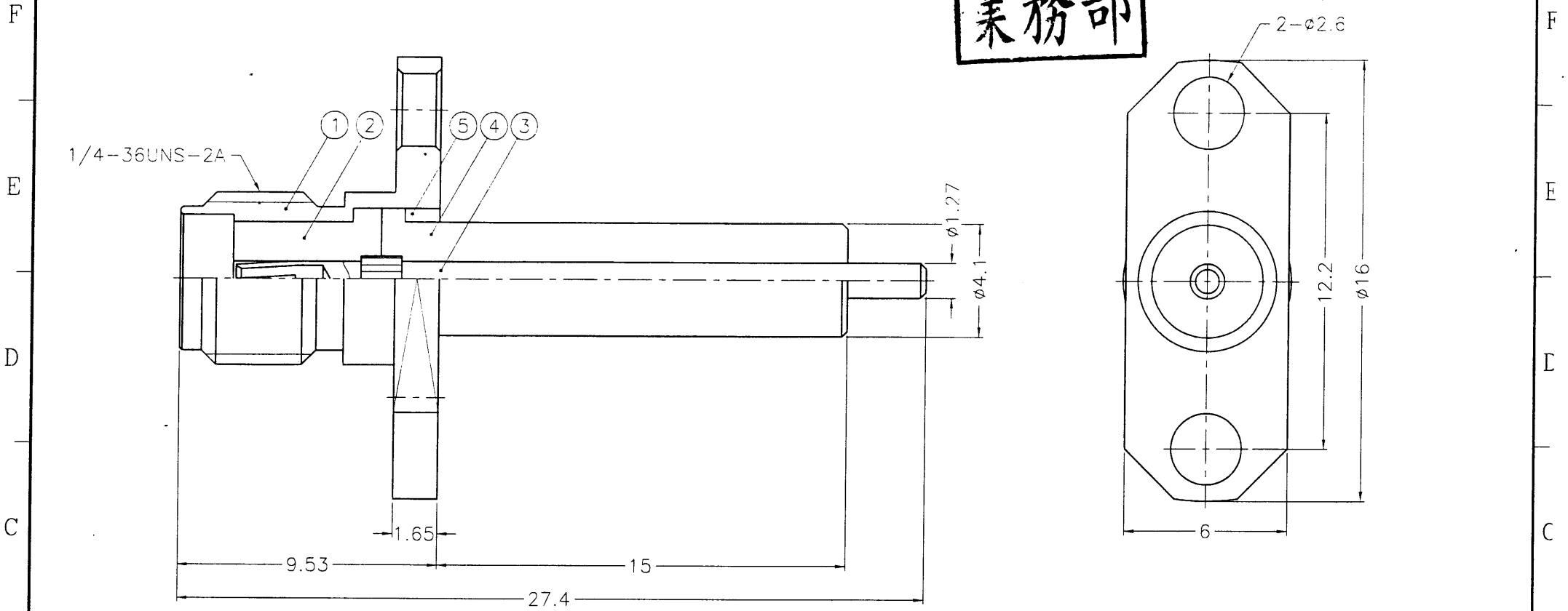

- NOTES: FINISH (PLATING THICKNESS IN MICRO-INCHES)
1. BRASS PER QQ-B-626
 2. GOLD PL. 3 MIN. THICK OVER NICKEL PL. 100 MIN. THICK OVER COPPER STRIKE
 3. BERYLLIUM COPPER PER QQ-C-530
 4. GOLD PL. 50 MIN. THICK OVER NICKEL PL. 100 MIN. THICK OVER COPPER STRIKE
 5. TEFLON MIL-P-19468

出圖
87.8.04
R&D

DIMENSIONS ARE IN MILLIMETERS						PART NO.			
NO.	DESCRIPTION	MATERIAL	FINISH	Q'TY	DRAWING NO.	UNLESS OTHERWISE SPECIFIED TOLERANCES	APPROVED		TITLE
5	RING	NOTE 1	NOTE 2	1	SMA7530-5-B	0.5-6 = ±0.2	DATE 08-03-98'	SMA PANEL RECEPT. JACK	
4	INSULATOR	NOTE 5	NATURAL	1	SMA7550-4T-50	6-30 = ±0.4	DATE 08-03-98'		
3	CONTACT PIN	NOTE 3	NOTE 4	1	SMA7550-3	30-120 = ±0.6	DATE 08-03-98'	DRAWING NO. KJ-SMA6551F1-3GT50G-50	
2	INSULATOR	NOTE 5	NATURAL	1	SMA7530-2T-50-B	120-315 = ±1	DATE 08-03-98'		
1	BODY	NOTE 1	NOTE 2	1	SMA7535-1-B	315-1000 = ±1.6	DATE 08-03-98'	FILE NO. F:\DWG\SMA\6551F1\50\3GT50G	
						1000-2000 = ±2.4	DATE 08-03-98'		
						SCALE 5/1	ISSUE A		

APPROVED Mark C
CHECKED Mark C
DRAWN Betty L.

1 2 3 4 5 6 7 8 85MA-R1282