

REVISIONS		
ISS	ZONE	DESCRIPTION\APPROVED\DATE

業務部

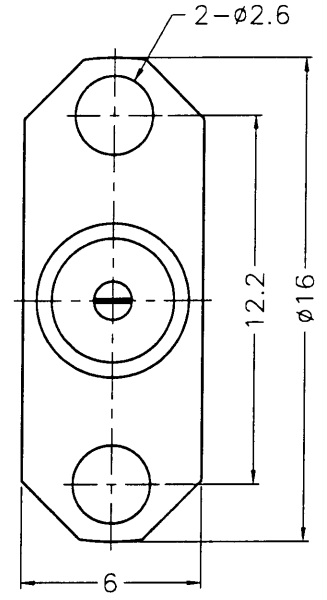
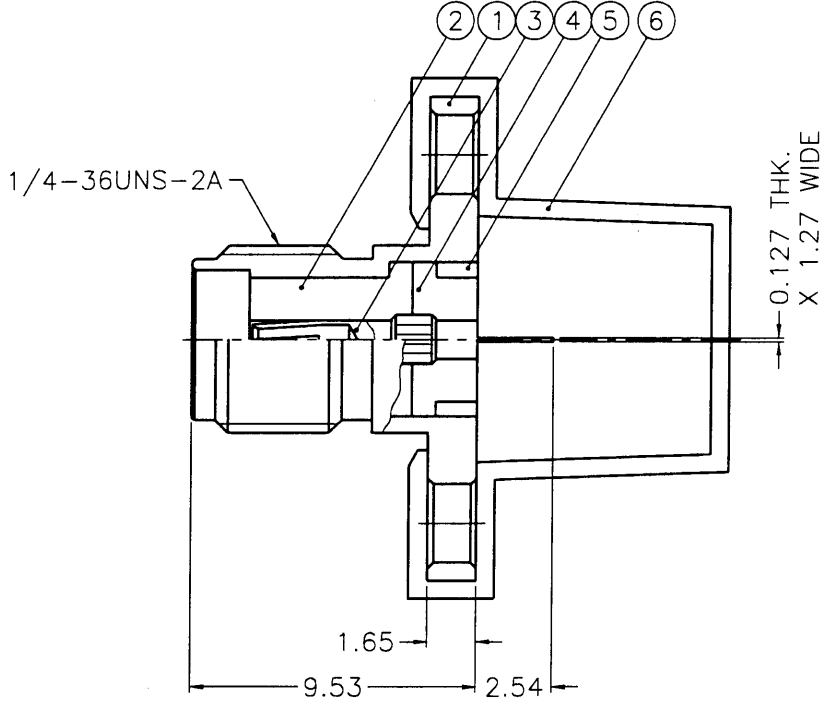

HORIZONTAL TAB

NOTES: FINISH (PLATING THICKNESS IN MICRO-INCHES)  
 1. BRASS PER QQ-B-626  
 2. GOLD PL. 3 MIN. THICK OVER NICKEL PL. 100 MIN. THICK OVER COPPER STRIKE  
 3. BERYLLIUM COPPER PER QQ-C-530  
 4. GOLD PL. 50 MIN. THICK OVER NICKEL PL. 100 MIN. THICK OVER COPPER STRIKE  
 5. TEFLON MIL-P-19468

出圖  
87.9.10  
R&D

DIMENSIONS ARE IN MILLIMETERS					PART NO.		KAI JACK INDUSTRIAL CO., LTD. TAINAN TAIWAN R.O.C.				
6	COVER	PE	NATURAL	1	SMA1551M1-9	APPROVED	DATE	TITLE			
5	RING	NOTE 1	NOTE 2	1	SMA7530-5-B				Mark C Mark C Betty S	DATE	SMA PANEL RECEPTACLE JACK
4	INSULATOR	NOTE 5	NATURAL	1	SMA7530-4T-50	CHECKED	09-09-98'				
3	CONTACT PIN	NOTE 3	NOTE 4	1	SMA6551M1-3	DRAWN	09-09-98'				
2	INSULATOR	NOTE 5	NATURAL	1	SMA7530-2T-50-B		DATE	DRAWING NO.			
1	BODY	NOTE 1	NOTE 2	1	SMA7535-1-B		09-09-98'	KJ-SMA6551N1-3GT50G-50			
NO.	DESCRIPTION	MATERIAL	FINISH	Q'TY	DRAWING NO.	SCALE	4/1	ISSUE	A	FILE NO.	F:\DWG\SMA\6551N1\50\3GT50G

BSMAR1318

E  
D  
C  
B  
A

F  
E  
D  
C  
E  
A