

業務部

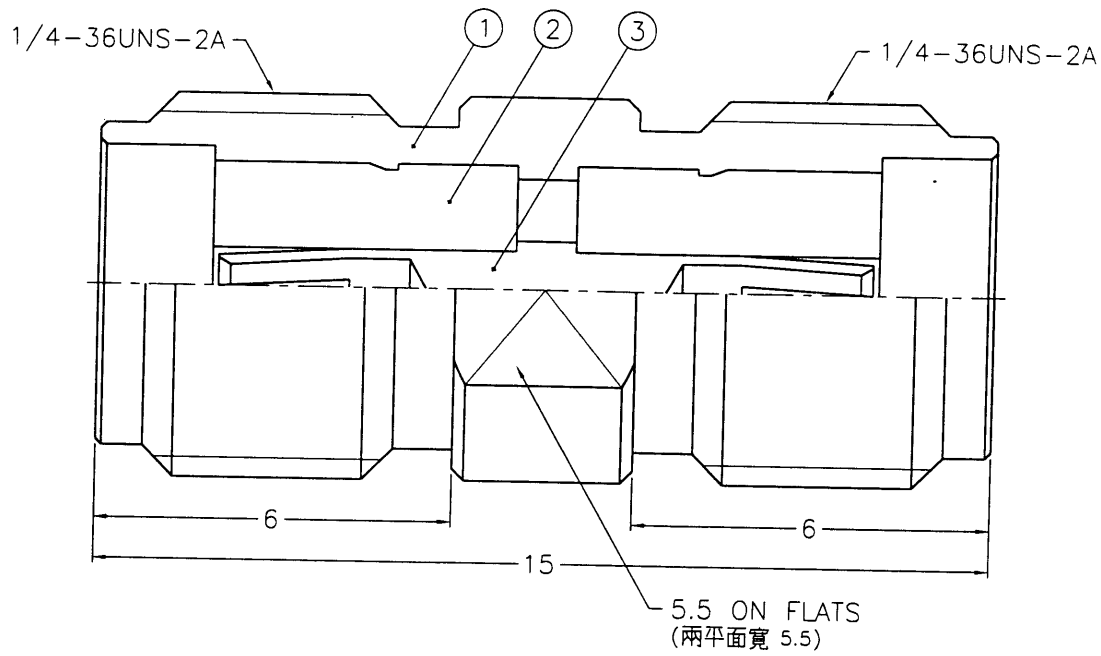

NOTES: FINISH (PLATING THICKNESS IN MICRO-INCHES)

- 1. BRASS PER QQ-B-626
- 2. GOLD PL. 3 MIN. THICK OVER NICKEL PL. 100 MIN. THICK OVER COPPER STRIKE
- 3. BERYLLIUM COPPER PER QQ-C-530
- 4. GOLD PL. 50 MIN. THICK OVER NICKEL PL. 100 MIN. THICK OVER COPPER STRIKE
- 5. TEFLON MIL-P-19468

88.5.24
 88012061

DIMENSIONS ARE IN MILLIMETERS
 UNLESS OTHERWISE SPECIFIED TOLERANCES
 0.5-6 = ±0.2
 6-30 = ±0.4
 30-120 = ±0.6
 120-315 = ±1
 315-1000 = ±1.6
 1000-2000 = ±2.4

PART NO.
 APPROVED *Mark C* DATE 05-19-99'
 CHECKED *Mark C* DATE 05-19-99'
 DRAWN *Betty S* DATE 05-19-99'



KAI JACK INDUSTRIAL CO., LTD.
 TAINAN TAIWAN R.O.C.

TITLE
 SMA FEMALE TO FEMALE ADAPTOR
 DRAWING NO.
 KJ-SMA7071A2-3GT50G-50
 FILE NO. F:\DWG\SMA\7071A2\50\3GT50G

NO.	DESCRIPTION	MATERIAL	FINISH	Q'TY	DRAWING NO.
3	CONTACT PIN	NOTE 3	NOTE 4	1	SMA7071A2-3-A
2	INSULATOR	NOTE 5	NATURAL	2	SMA7071A2-2T-50-B
1	BODY	NOTE 1	NOTE 2	1	SMA7071A2-1-C

88012061