

業務部

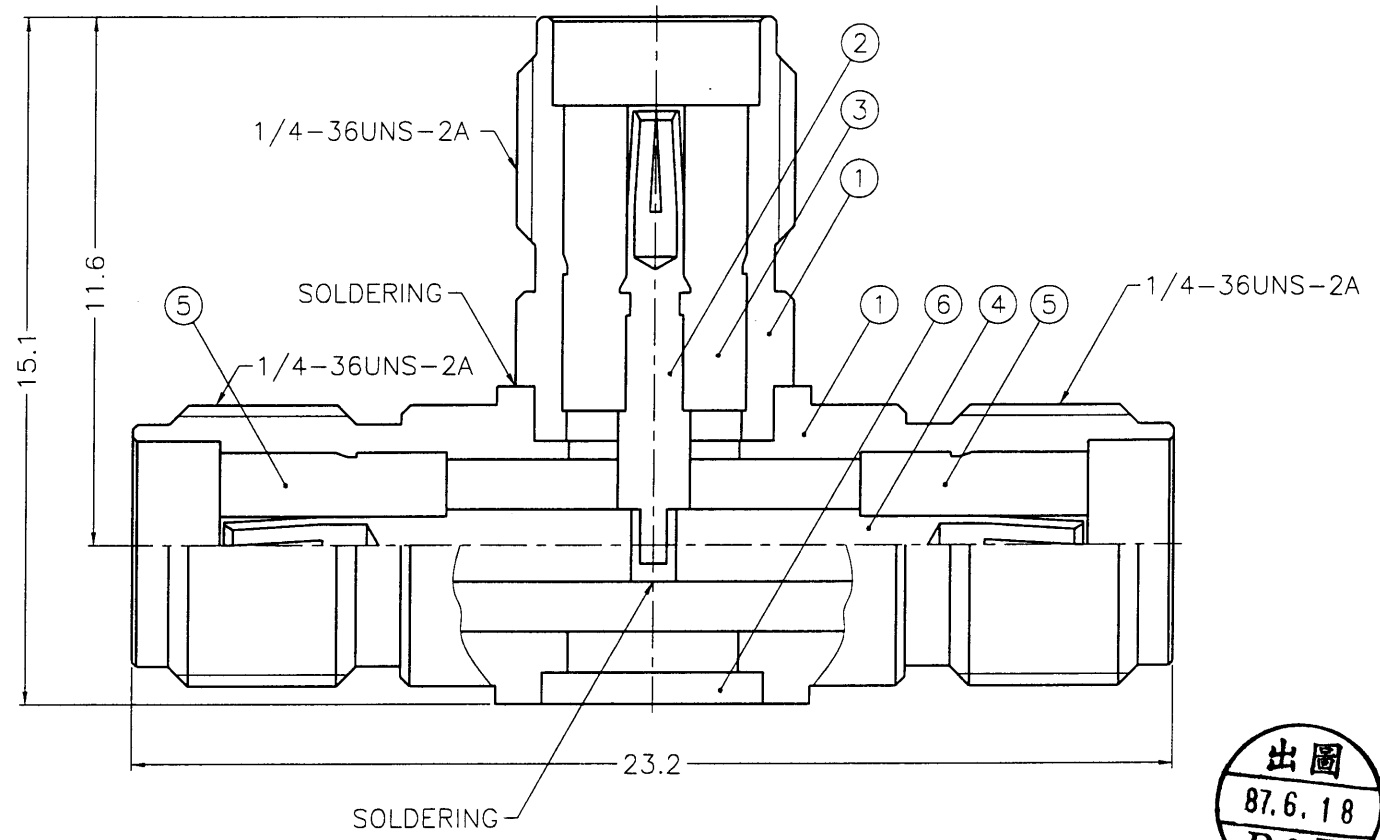

- NOTES: 1. PER KAI JACK SPEC. EP-SS-9700
 2. BRASS PER QQ-B-626
 STAINLESS STEEL PER QQ-S-764, TYPE 303
 3. BRASS PER QQ-B-626
 4. BERYLLIUM COPPER PER QQ-C-530
 5. TEFLON MIL-P-19468
 6. BRASS PER QQ-B-613

出圖
87.6.18
R&D

6	COVER	NOTE 6	NOTE 1	1	CV-5X05-T	DIMENSIONS ARE IN MILLIMETERS UNLESS OTHERWISE SPECIFIED TOLERANCES 0.5-6 = ±0.2 6-30 = ±0.4 30-120 = ±0.6 120-315 = ±1 315-1000 = ±1.6 1000-2000 = ±2.4	PART NO.			TITLE	
5	INSULATOR	NOTE 5	NATURAL	2	SMA7071A2-2T-50-B		APPROVED <i>[Signature]</i> DATE 06-11-98'			SMA "T" ADAPTOR JACK-JACK-JACK	
4	CONTACT PIN	NOTE 4	NOTE 1	1	SMA8073A1-4		CHECKED <i>[Signature]</i> DATE 06-11-98'			DRAWING NO. KJ-SMA8073A1-50	
3	INSULATOR	NOTE 5	NATURAL	1	SMA6252A2-3T-50-B		DRAWN <i>[Signature]</i> DATE 06-11-98'			FILE NO. F:\DWG\SMA\8073A1\50	
2	CONTACT PIN	NOTE 4	NOTE 1	1	SMA8073A1-2						
1	HOUSING WITH BODY	NOTE 2	NOTE 1	1	SMA8073A1-1S						
NO.	DESCRIPTION	MATERIAL	FINISH	Q'TY	DRAWING NO.	SCALE	6/1	ISSUE	A		