

REVISIONS		
ISS	ZONE	DESCRIPTION\APPROVED\DATE

業務部

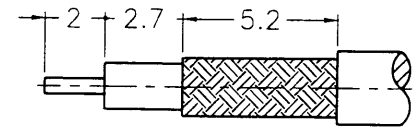

RECOMMENDED CABLE STRIPPING DIM'S

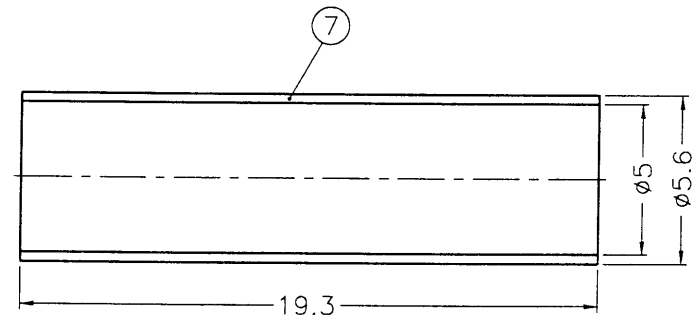
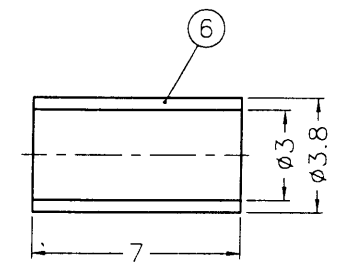
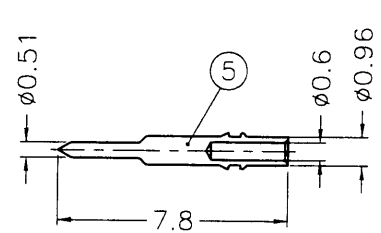
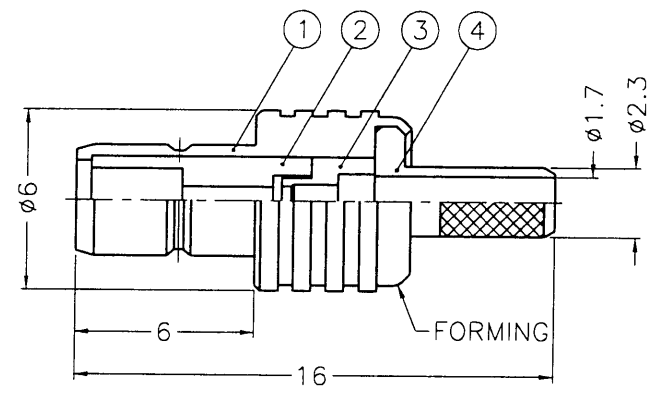

NOTES: FINISH (PLATING THICKNESS IN MICRO-INCHES)
 1. BRASS PER QQ-B-626
 2. GOLD PL. 3 MIN. THICK OVER NICKEL PL. 100 MIN. THICK OVER COPPER STRIKE
 3. GOLD PL. 30 MIN. THICK OVER NICKEL PL. 100 MIN. THICK OVER COPPER STRIKE
 4. TEFLON MIL-P-19468

NO.	DESCRIPTION	MATERIAL	FINISH	Q'TY	DRAWING NO.
7	HEAT SHRINK TUBING			1	HT-56/5X193
6	FERRULE	COPPER	NOTE 2	1	FR-38/3X7C
5	CONTACT PIN	NOTE 1	NOTE 3	1	SMB1121A1-5-096/06
4	BARREL	NOTE 1	NOTE 2	1	SMB6121A1-4-23/17-C
3	INSULATOR	NOTE 4	NATURAL	1	SMB6121B2-3T-50
2	INSULATOR	NOTE 4	NATURAL	1	SMB1121A1-2T-50
1	BODY	NOTE 1	NOTE 2	1	SMB1121A1-1-B

DIMENSIONS ARE IN MILLIMETERS
 UNLESS OTHERWISE SPECIFIED TOLERANCES
 0.5-6 = ±0.2
 6-30 = ±0.4
 30-120 = ±0.6
 120-315 = ±1
 315-1000 = ±1.6
 1000-2000 = ±2.4

PART NO.	
APPROVED	DATE 08-24-98'
CHECKED	DATE 08-24-98'
DRAWN	DATE 08-24-98'

KAI JACK INDUSTRIAL CO., LTD.
 TAINAN TAIWAN R.O.C.

TITLE: SMB CRIMP JACK (FOR RG-174/U,188A/U,316/U)

DRAWING NO. KJ-SMB1121A1-3GT30G-316U-50

FILE NO. F:\DWG\SMB\1121A1\316U-50\3GT30G

出圖
 87.8.25
 R&D