

1 2 3 4 5 6 7 8

REVISIONS		
ISS	ZONE	DESCRIPTION\PER REQUEST\DATE

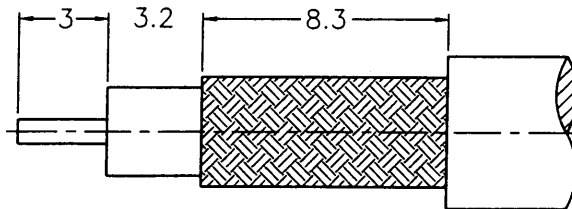

RECOMMENDED  
CABLE STRIPPING DIM'S  
(建議剝線尺寸)

**SALES**

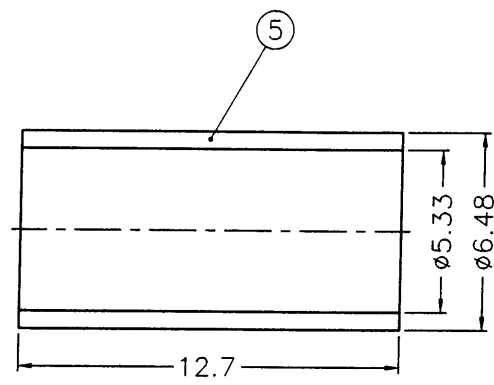
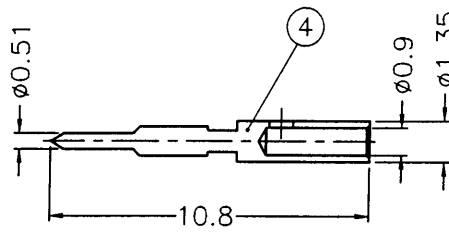
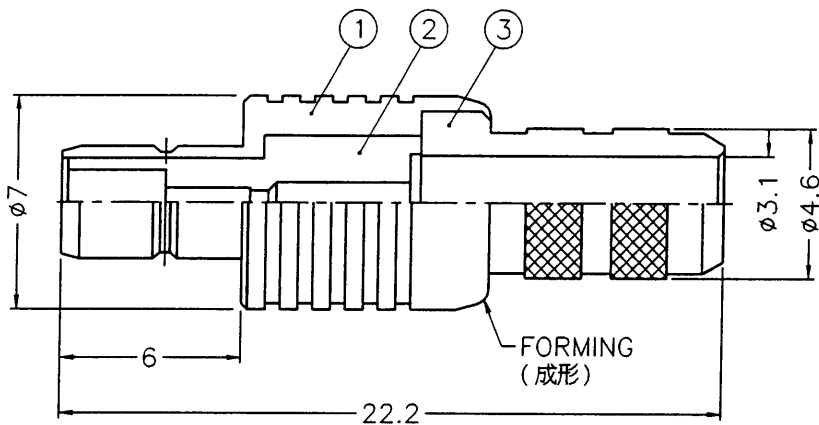

NOTES: FINISH (PLATING THICKNESS IN MICRO-INCHES)  
 1. BRASS PER QQ-B-626  
 2. NICKEL PL. 100 MIN. THICK OVER COPPER STRIKE  
 3. GOLD PL. 30 MIN. THICK OVER NICKEL PL. 100 MIN. THICK OVER COPPER STRIKE  
 4. TEFLON MIL-P-19468

- 1. CRIMPED FERRULE  
HEX CRIMP SIZE .213"
- 2. CRIMPED CONTACT PIN  
SQ. CRIMP SIZE .043

ISSUED  
2001 10. 19  
R & D

DIMENSIONS ARE IN MILLIMETERS					PART NO.		Amphenol - Kai Jack TAINAN TAIWAN				
UNLESS OTHERWISE SPECIFIED TOLERANCES					APPROVED	DATE					
5	FERRULE	COPPER	NOTE 2	1	FR-648/533X127C	<i>Andy C</i>	10-16-01'	TITLE SMB CRIMP JACK (FOR RG-58/U, 58B/U)			
4	CONTACT PIN	NOTE 1	NOTE 3	1	CP12ABBO1A		DATE				
3	BARREL	NOTE 1	NOTE 2	1	SMB6121A2-3-46/31	<i>Andy C</i>	10-16-01'	DRAWING NO. KJ-SMB1121A2-NT30G-58U-50			
2	INSULATOR	NOTE 4	NATURAL	1	NS12AAZ01A	DATE					
1	BODY	NOTE 1	NOTE 2	1	BD12ABC01A	<i>Stacy W</i>	10-16-01'	ITEM NO. 121121AAA58NC5F			
NO.	DESCRIPTION	MATERIAL	FINISH	Q'TY	DRAWING NO.	SCALE	4/1		ISSUE	A1	FILE NO.

RD-DR13032