

1 2 3 4 5 6 7 8

REVISIONS		
ISS	ZONE	DESCRIPTION\PER REQUEST\DATE
B	A-3	NO.5 WAS CHANGED\RD-DM88090201B\09-02-99'
C	A-3	NO.2 WAS CHANGED\RD-DA93090201E\09-14-04'

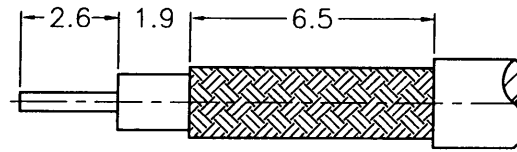

RECOMMENDED  
CABLE STRIPPING DIM'S  
(建議剝線尺寸)

SALES

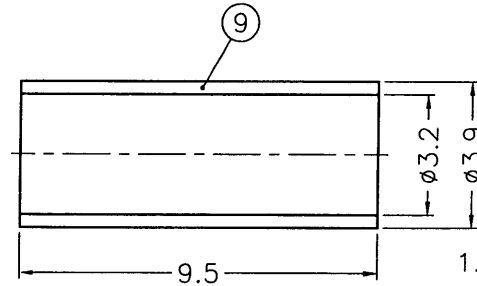
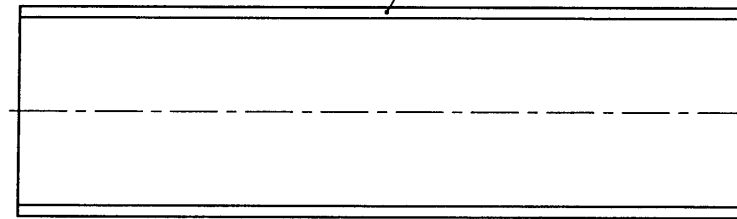
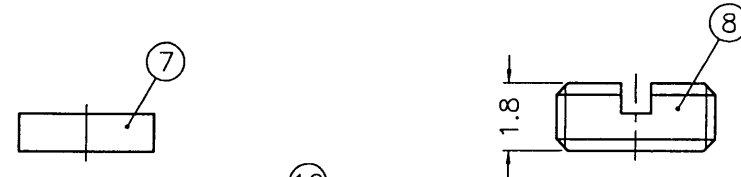
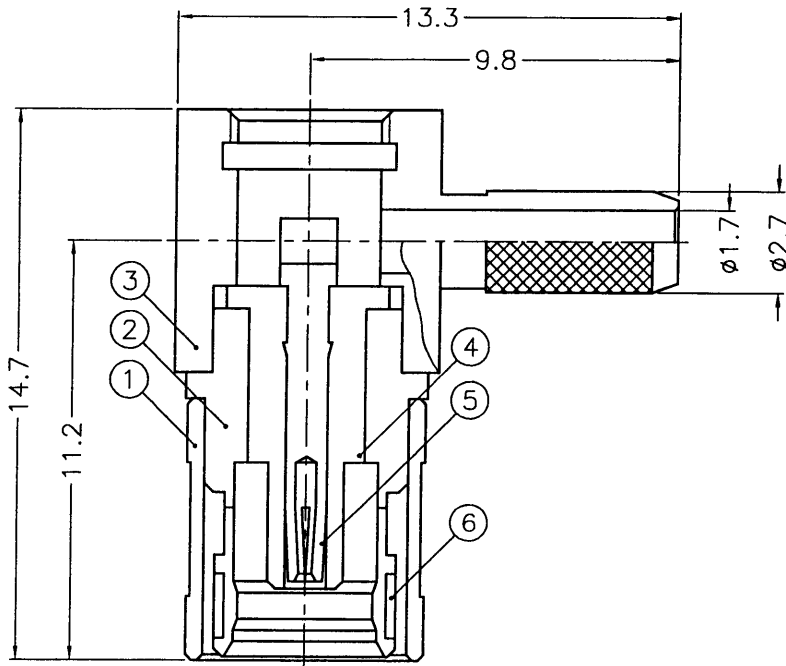

1. CRIMPED FERRULE  
HEX CRIMP SIZE .128"

ISSUED  
2004. 9. 14  
R&D

- NOTES: FINISH (PLATING THICKNESS IN MICRO-INCHES)
1. BRASS PER QQ-B-626
  2. GOLD PL. 3 MIN. THICK OVER NICKEL PL. 100 MIN. THICK OVER COPPER STRIKE
  3. BERYLLIUM COPPER PER QQ-C-530
  4. GOLD PL. 30 MIN. THICK OVER NICKEL PL. 100 MIN. THICK OVER COPPER STRIKE
  5. TEFLON MIL-P-19468
  6. JIS H 3250, C 2600

10	HEAT SHRINK TUBING			1	HT-56/5X193
9	FERRULE	NOTE 6	NOTE 2	1	FR-39/32X95
8	COVER	NOTE 1	NOTE 2	1	SMA1112A3-8-B
7	INSULATOR	PE	NATURAL	1	SMB5090-7
6	RETAINER RING	NOTE 3	NATURAL	1	SMB5000-6
5	CONTACT PIN	NOTE 3	NOTE 4	1	SMB5090-5-B
4	INSULATOR	NOTE 5	NATURAL	1	SMB5090-4T-50
3	BARREL	NOTE 1	NOTE 2	1	SMB5090-3-27/17-A
2	BODY	NOTE 1	NOTE 2	1	SMB5090-2-B
1	SHELL	NOTE 1	NOTE 2	1	SMB5000-1
NO.	DESCRIPTION	MATERIAL	FINISH	Q'TY	DRAWING NO.

DIMENSIONS ARE IN MILLIMETERS  
UNLESS OTHERWISE SPECIFIED TOLERANCES

0.5-6	= ±0.2
6-30	= ±0.4
30-120	= ±0.6
120-315	= ±1
315-1000	= ±1.6
1000-2000	= ±2.4

PART NO.	
APPROVED	Scott.H 09-14-04'
CHECKED	Scott.H 09-14-04'
DRAWN	Enya 09-14-04'
FILE NO. F:\DWG\SMB\6112A1\316U-50\3GT30G-C	

Amphenol	
Danbury,CT,USA-Tainan,Taiwan-Shenzhen,China	
TITLE	SMB R/A CRIMP PLUG (FOR RG-174/U,188A/U,316/U)
DRAWING NO.	SMB6112A1-3GT30G-316U-50
ITEM NO.	126112AAB36GE5F

7RD-DR 2969 8