

1 2 3 4 5 6 7 8

| REVISIONS | | |
|-----------|------|---|
| ISS | ZONE | DESCRIPTION\PER REQUEST\DATE |
| B | A-1 | NO.5 WAS CHANGED\RD-DM88090201B\09-02-99' |

業務部

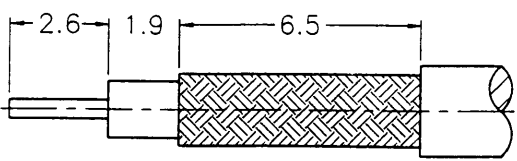

RECOMMENDED
CABLE STRIPPING DIM'S
(建議剝線尺寸)

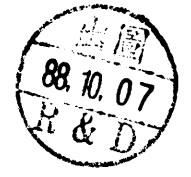
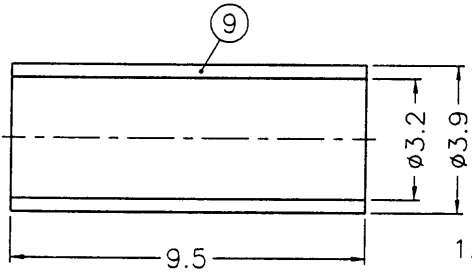
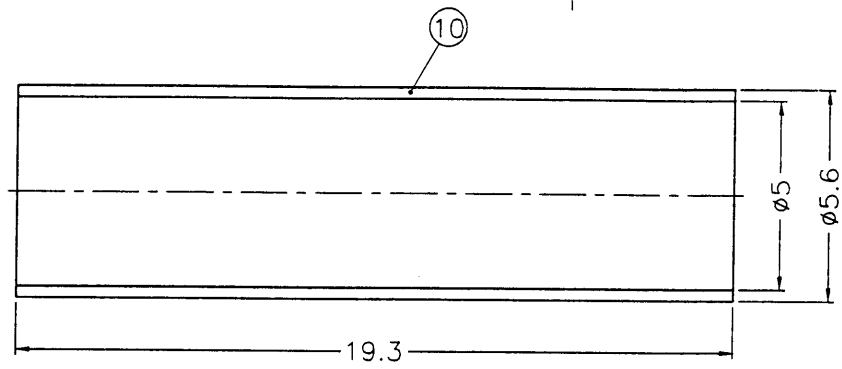
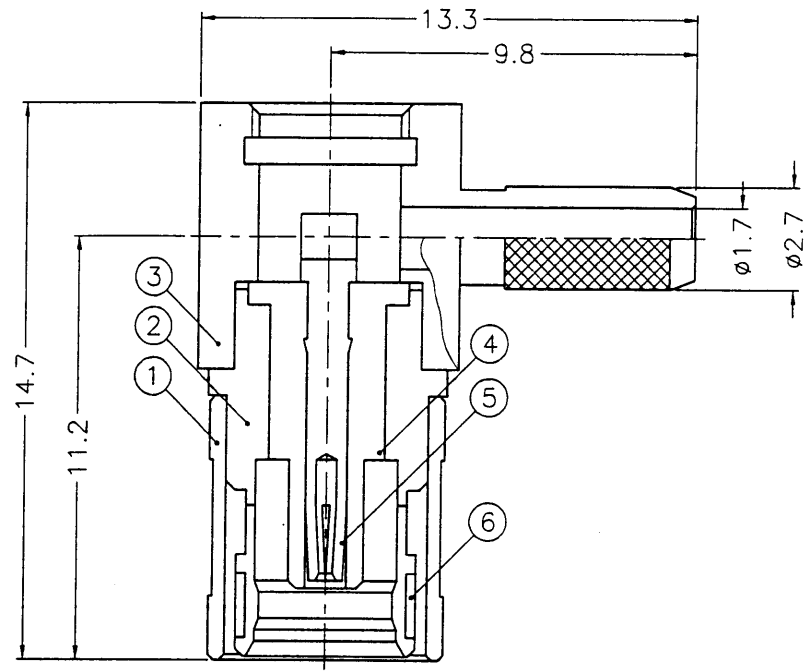
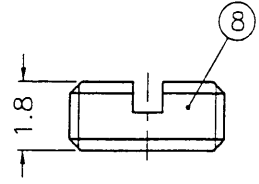
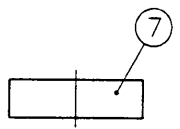

NOTES: FINISH (PLATING THICKNESS IN MICRO-INCHES)

- BRASS PER QQ-B-626
- NICKEL PL. 100 MIN. THICK OVER COPPER STRIKE
- BERYLLIUM COPPER PER QQ-C-530
- GOLD PL. 30 MIN. THICK OVER NICKEL PL. 100 MIN. THICK OVER COPPER STRIKE
- TEFLON MIL-P-19468
- JIS H 3250, C 2700

1. CRIMPED FERRULE
HEX CRIMP SIZE .128"

| 10 | HEAT SHRINK TUBING | | | 1 | HT-56/5X193 |
|-----|--------------------|----------|---------|------|-------------------|
| 9 | FERRULE | NOTE 6 | NOTE 2 | 1 | FR-39/32X95 |
| 8 | COVER | NOTE 1 | NOTE 2 | 1 | SMA1112A3-8-B |
| 7 | INSULATOR | PE | NATURAL | 1 | SMB5090-7 |
| 6 | RETAINER RING | NOTE 3 | NATURAL | 1 | SMB5000-6 |
| 5 | CONTACT PIN | NOTE 3 | NOTE 4 | 1 | SMB5090-5-B |
| 4 | INSULATOR | NOTE 5 | NATURAL | 1 | SMB5090-4T-50 |
| 3 | BARREL | NOTE 1 | NOTE 2 | 1 | SMB5090-3-27/17-A |
| 2 | BODY | NOTE 1 | NOTE 2 | 1 | SMB5090-2-A |
| 1 | SHELL | NOTE 1 | NOTE 2 | 1 | SMB5000-1 |
| NO. | DESCRIPTION | MATERIAL | FINISH | Q'TY | DRAWING NO. |

DIMENSIONS ARE IN MILLIMETERS

UNLESS OTHERWISE SPECIFIED TOLERANCES

- 0.5-6 = ±0.2
- 6-30 = ±0.4
- 30-120 = ±0.6
- 120-315 = ±1
- 315-1000 = ±1.6
- 1000-2000 = ±2.4

| PART NO. | |
|----------|----------------|
| APPROVED | DATE 10-07-99' |
| CHECKED | DATE 10-07-99' |
| DRAWN | DATE 10-07-99' |

Amphenol - Kai Jack
TAINAN TAIWAN

| | |
|-------------|---|
| TITLE | SMB R/A CRIMP PLUG (FOR RG-174/U,188A/U,316/U) |
| DRAWING NO. | KJ-SMB6112A1-NT30G-316U-50 |
| FILE NO. | F:\DWG\SMB\6112A1\316U-50\NT30G |

F

E

D

C

B

A

1 2 3 4 5 6 7 8

SMBR0873