

REVISIONS			
ISS	ZONE	DESCRIPTION\PER REQUEST\DATE	
B	A-1	NO.5 WAS CHANGED\RD-DM88090201B\09-02-99'	

業務部

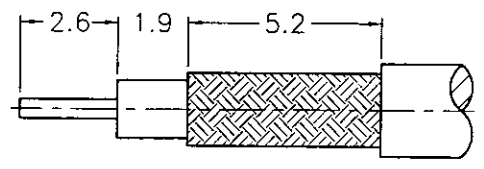

RECOMMENDED
CABLE STRIPPING DIM'S
(建議剝線尺寸)

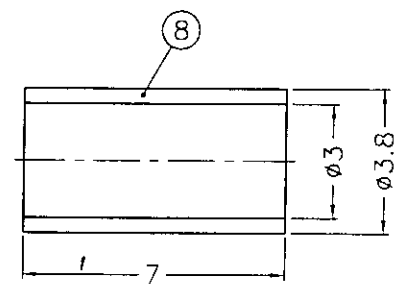
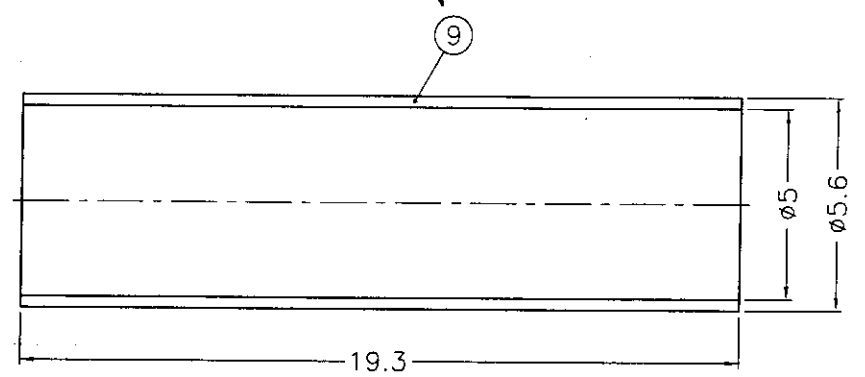
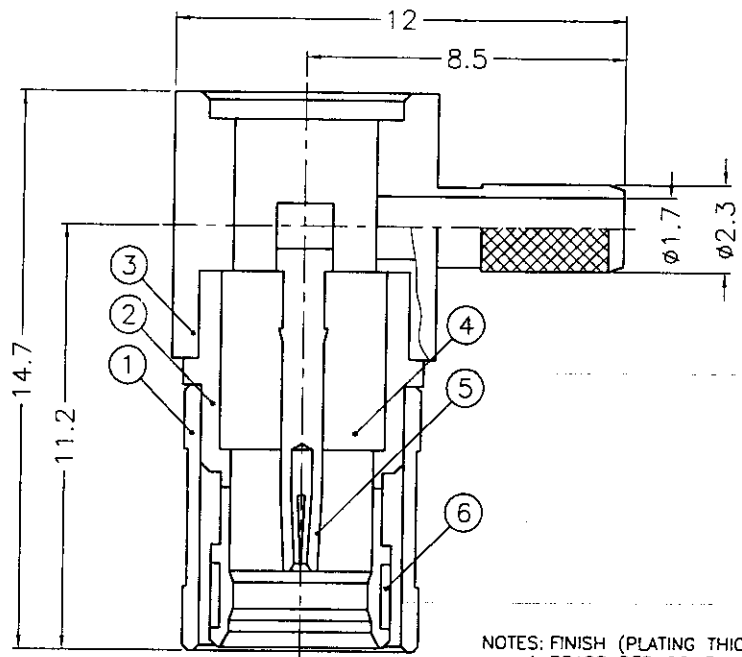
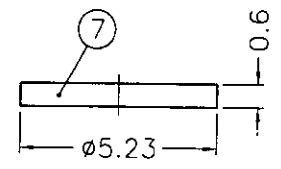

88.9.09
H&D

- NOTES: FINISH (PLATING THICKNESS IN MICRO-INCHES)
1. BRASS PER QQ-B-626
 2. BRASS PER QQ-B-613
 3. NICKEL PL. 100 MIN. THICK OVER COPPER STRIKE
 4. BERYLLIUM COPPER PER QQ-C-530
 5. GOLD PL. 30 MIN. THICK OVER NICKEL PL. 100 MIN. THICK OVER COPPER STRIKE
 6. TEFLON MIL-P-19468

1. CRIMPED FERRULE
HEX CRIMP SIZE .128"

9	HEAT SHRINK TUBING			1	HT-56/5X193
8	FERRULE	COPPER	NOTE 3	1	FR-38/3X7C
7	COVER	NOTE 2	NOTE 3	1	CV-523X06-T
6	RETAINER RING	NOTE 4	NATURAL	1	SMB5000-6
5	CONTACT PIN	NOTE 4	NOTE 5	1	SMB5090-5-B
4	INSULATOR	NOTE 6	NATURAL	1	SMB6112AA-4T-75
3	BARREL	NOTE 1	NOTE 3	1	SMB6112AA-3-23/17
2	BODY	NOTE 1	NOTE 3	1	SMB6112AA-2-75
1	SHELL	NOTE 1	NOTE 3	1	SMB5000-1

DIMENSIONS ARE IN MILLIMETERS
UNLESS OTHERWISE SPECIFIED TOLERANCES

0.5-6	= ±0.2
6-30	= ±0.4
30-120	= ±0.6
120-315	= ±1
315-1000	= ±1.6
1000-2000	= ±2.4

PART NO.	
APPROVED	DATE 09-08-99'
CHECKED	DATE 09-08-99'
DRAWN	DATE 09-08-99'

Amphenol - Kai Jack	
TAINAN TAIWAN	
TITLE	MINI 75 OHM SMB R/A CRIMP PLUG
DRAWING NO.	KJ-SMB6112AA-NT30G-179U-75
FILE NO.	F:\DWG\SMB\6112AA\179U-75\NT30G

B
C
D
E
F
A