

REVISIONS		
ISS	ZONE	DESCRIPTION\PER REQUEST\DATE
B	A-1	NO.2 WAS CHANGED\RD-DM93032501L\03-25-04'

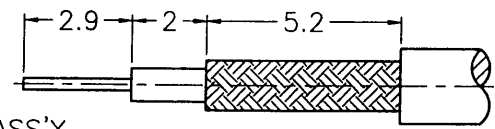

RECOMMENDED
CABLE STRIPPING DIM'S
(建議剝線尺寸)

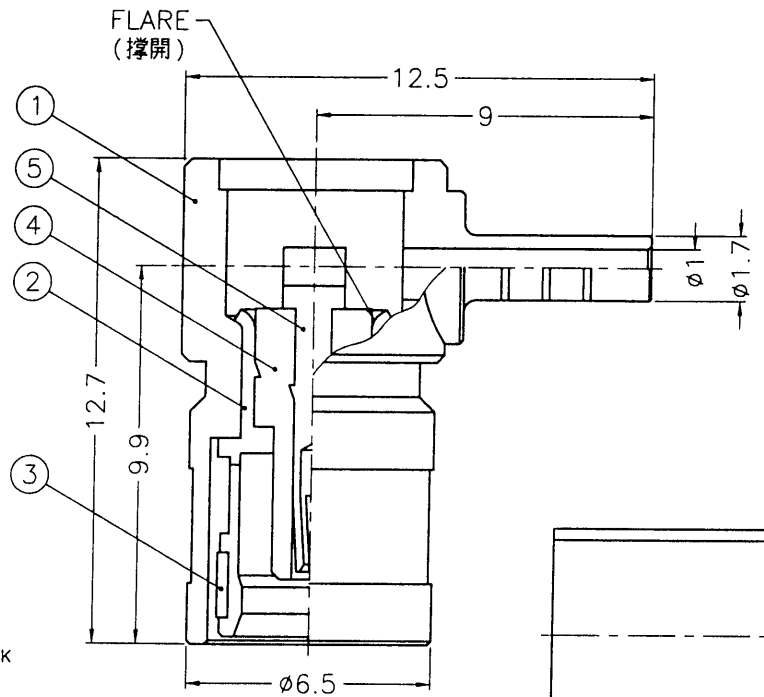
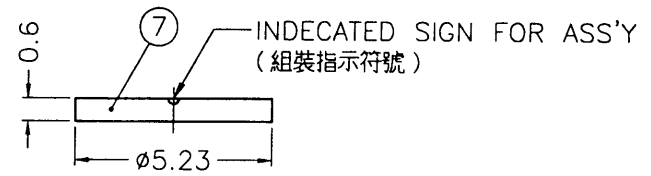

SALES

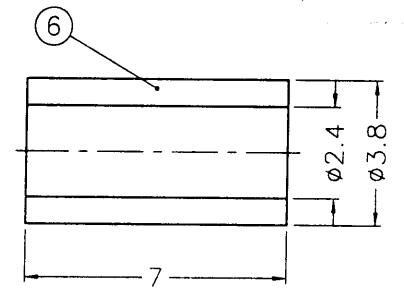

ISSUED
2004. 3. 30
R&D

NOTES: FINISH (PLATING THICKNESS IN MICRO-INCHES)
 1. BRASS PER QQ-B-626
 2. BRASS PER QQ-B-613
 3. NICKEL PL. 100 MIN. THICK OVER COPPER STRIKE
 4. NICKEL PL. 100 MIN. THICK OVER COPPER PL. 300 MIN. THICK
 5. BERYLLIUM COPPER PER QQ-C-530
 6. GOLD PL. 30 MIN. THICK OVER NICKEL PL. 100 MIN. THICK OVER COPPER STRIKE
 7. TEFLON MIL-P-19468

1. CRIMPED FERRULE
HEX CRIMP SIZE .128"
2. CONTACT PIN TO SOLDER

NO.	DESCRIPTION	MATERIAL	FINISH	Q'TY	DRAWING NO.
8	HEAT SHRINK TUBING			1	HT-56/5X193
7	COVER	NOTE 2	NOTE 3	1	CV-523X06-T-B
6	FERRULE	COPPER	NOTE 3	1	FR-38/24X7C
5	CONTACT PIN	NOTE 5	NOTE 6	1	SMB5091-5-B
4	INSULATOR	NOTE 7	NATURAL	1	SMB5003-3T-50
3	RETAINER RING	NOTE 5	NATURAL	1	SMB5000-6
2	BODY	NOTE 1	NOTE 3	1	SMB6112D1-2-D
1	HOUSING	DIECAST	NOTE 4	1	HS12AAA03A

DIMENSIONS ARE IN MILLIMETERS				PART NO.	
UNLESS OTHERWISE SPECIFIED TOLERANCES				APPROVED	DATE
0.5-6 = ±0.2				<i>Shaly.w</i>	03-25-04'
6-30 = ±0.4				CHECKED	DATE
30-120 = ±0.6				<i>Shaly.w</i>	03-25-04'
120-315 = ±1				DRAWN	DATE
315-1000 = ±1.6				<i>jen</i>	03-25-04'
1000-2000 = ±2.4					
SCALE	5/1	ISSUE	B	FILE NO.	F:\DWG\SMB\6112D1\196AU-50\NT30G-B

Amphenol	
Danbury,CT,USA-Tainan,Taiwan-Shenzhen,China	
TITLE	SMB R/A CRIMP PLUG (FOR RG-178B/U,196A/U)
DRAWING NO.	SMB6112D1-NT30G-196AU-50
ITEM NO.	126112AAC16NC5F

RD-DR 20880