

1 2 3 4 5 6 7 8

REVISIONS		
ISS	ZONE	DESCRIPTION\APPROVED\DATE

業務部

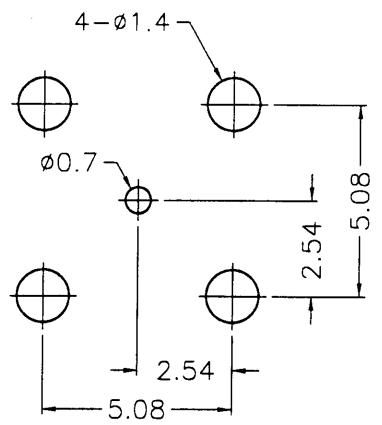

PCB MOUNTING HOLES

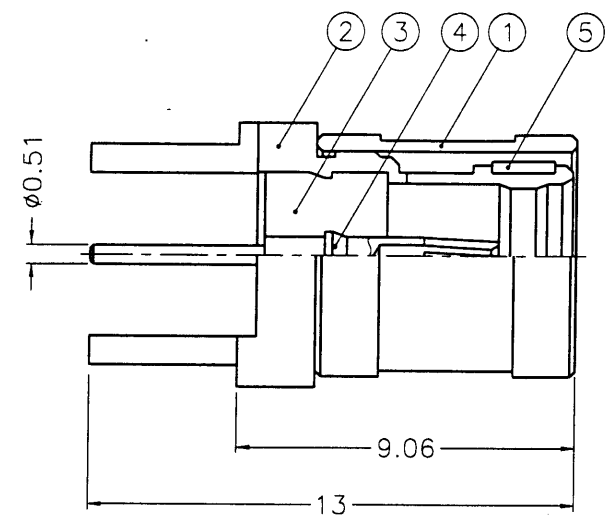
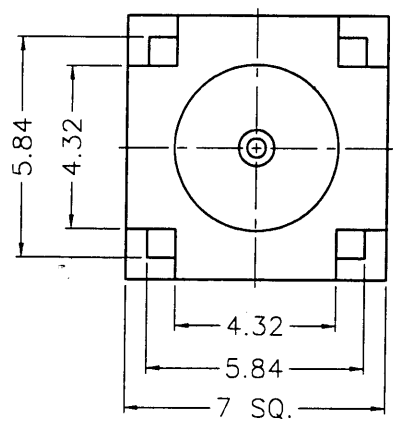

- NOTES: FINISH (PLATING THICKNESS IN MICRO-INCHES)
1. BRASS PER QQ-B-626
 2. GOLD PL. 3 MIN. THICK OVER NICKEL PL. 100 MIN. THICK OVER COPPER STRIKE
 3. BERYLLIUM COPPER PER QQ-C-530
 4. GOLD PL. 30 MIN. THICK OVER NICKEL PL. 100 MIN. THICK OVER COPPER STRIKE
 5. TEFLON MIL-P-19468

出圖
87.11.24
R&D

NO.	DESCRIPTION	MATERIAL	FINISH	Q'TY	DRAWING NO.
5	RETAINER RING	NOTE 3	NATURAL	1	SMB5000-6
4	CONTACT PIN	NOTE 3	NOTE 4	1	SMB6251M1-4-75
3	INSULATOR	NOTE 5	NATURAL	1	SMB6251M1-3T-75
2	BODY	NOTE 1	NOTE 2	1	SMB6251M1-2
1	SHELL	NOTE 1	NOTE 2	1	SMB5000-1

DIMENSIONS ARE IN MILLIMETERS			
UNLESS OTHERWISE SPECIFIED	TOLERANCES		
0.5-6	= ±0.2		
6-30	= ±0.4		
30-120	= ±0.6		
120-315	= ±1		
315-1000	= ±1.6		
1000-2000	= ±2.4		
SCALE	5/1	ISSUE	A

PART NO.	
APPROVED	DATE 11-19-98'
CHECKED	DATE 11-19-98'
DRAWN	DATE 11-19-98'

KAI JACK INDUSTRIAL CO., LTD. TAINAN TAIWAN R.O.C.	
TITLE	
MINI 75 OHM SMB P.C. MOUNT PLUG	
DRAWING NO.	
KJ-SMB6251M1-3GT30G-75	
FILE NO. F:\DWG\SMB\6251M1\75\3GT30G	

F
E
D
C
B
A

F
E
D
C
B
A

1 2 3 4 5 6 7 8

SMB-R0672